

VAL-MATIC®

SURGEBUSTER!

Bulletin 7200

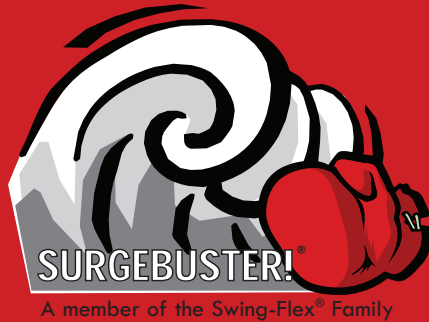

**BUILT WITH
ADVANCED
TECHNOLOGY
TO WITHSTAND
YOUR TOUGHEST
APPLICATIONS**

Air Release Air Valves

Air/Vacuum Air Valves

Combination Air Valves

Well Service Air Valves

Wastewater Air Valves

Anti-Slam Air Valves

Vacuum Relief Air Valves

SURGEBUSTER® Check Valves

Tilted Disc® Check Valves

Swing-Flex® Check Valves

Dual Disc® Check Valves

Silent Check Valves

American-BFV® Butterfly Valves

Cam-Centric® Plug Valves

Sure Seal Foot Valves

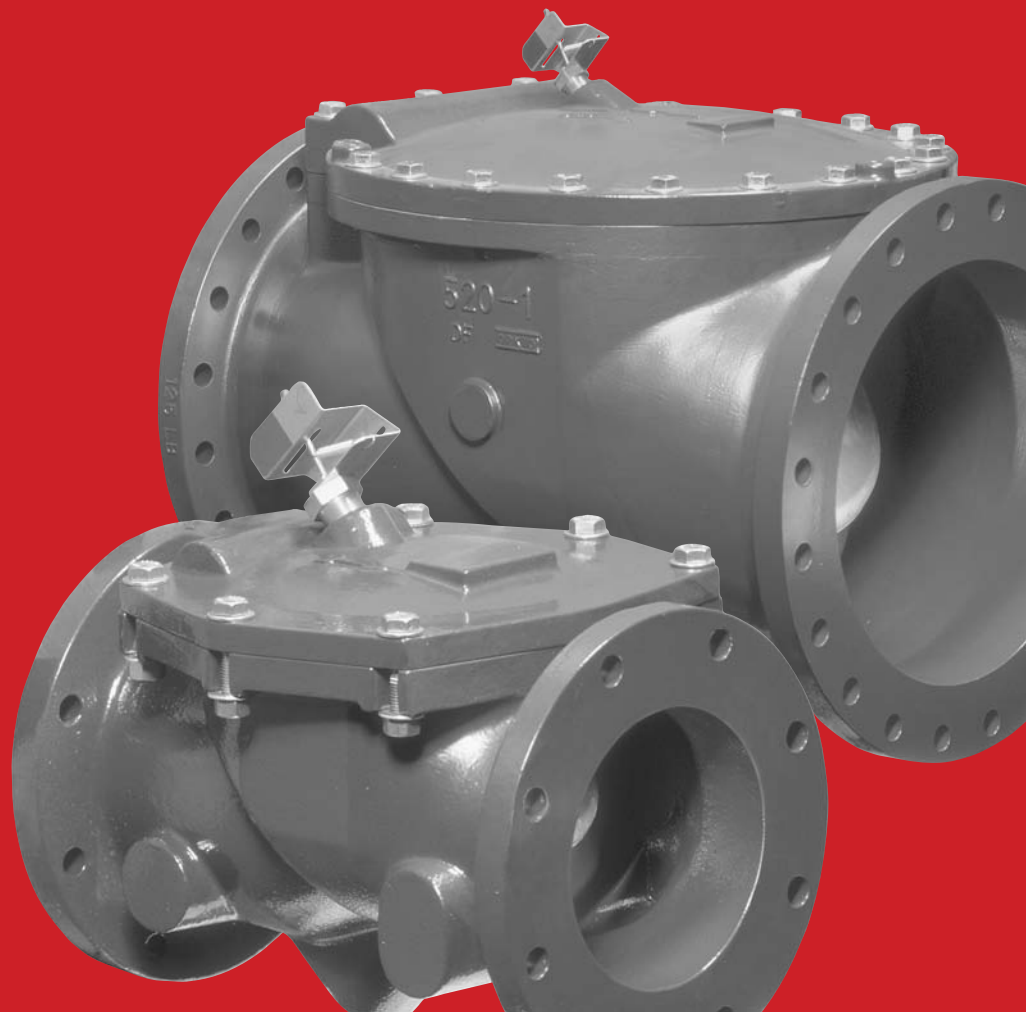

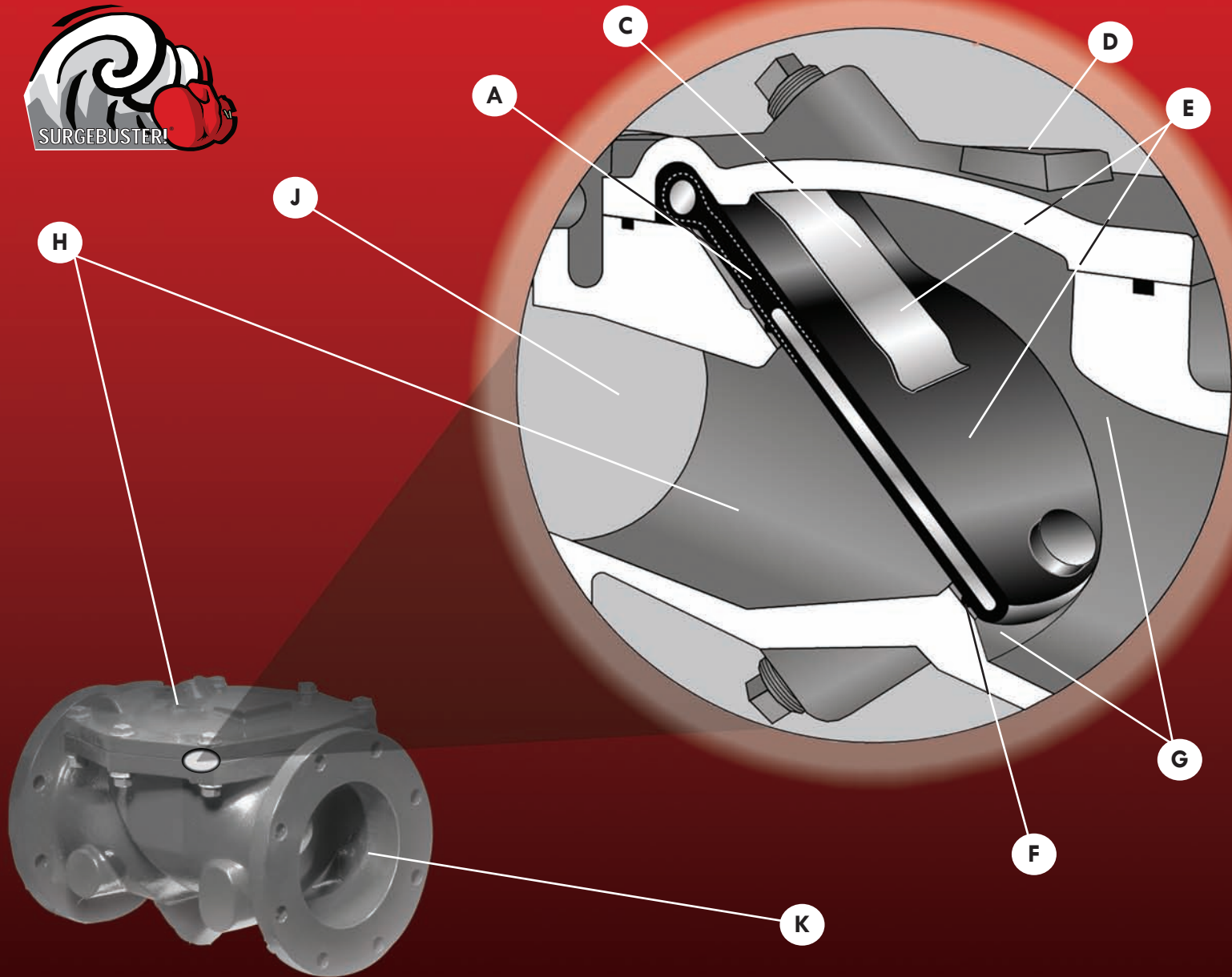

A. REINFORCED DISC

The one piece precision molded disc is steel and nylon reinforced to provide years of trouble free performance. It is backed by a 25 year warranty for the flex portion of the disc.

B. MECHANICAL DISC POSITION INDICATOR* (Optional)

Provides clear indication of the valve's disc position. Can also be provided with a SCADA compatible limit switch for off site monitoring (Not shown, see options).

C. DISC ACCELERATOR™**

The signature SURGEBUSTER!® Disc Accelerator™ moves in perfect tandem with the reinforced disc to quickly and efficiently speed the closure of the disc. Warranted for 25 years!

D. DOMED ACCESS PORT

Full size top access port allows removal of disc without removing valve from line and

provides for flushing action over the valve disc for clog free performance. Access cover includes a drilled and tapped port for installation of optional Disc Position Indicator.

E. ONLY TWO MOVING PARTS

The Memory-Flex™ and Disc Accelerator™ are the only moving parts. There are no packing or O-rings, mechanical hinges, pivot pins or bearings to wear out. Hinge portion of disc is warranted for 25 years.

F. DROP TIGHT SEATING

The synthetic reinforced disc, with its integral O-ring type seal design, assures positive seating at high and low pressures.

G. NON-SLAM CLOSURE

"Short Disc Stroke" combined with Memory-Flex™ Disc action and the Disc Accelerator™ reduce potentially destructive water hammer.

H. FUSION BONDED EPOXY

Fusion Bonded Epoxy (FBE) is provided standard on the interior and exterior of the valve. The FBE is ANSI/NSF 61 certified. Other coatings are available on request.

I. BACKFLOW ACTUATOR (Optional)

Body is drilled and tapped for installation of optional backflow actuator (Not shown, see options).

J. NON-CLOG DESIGN

The unrestricted full flow area combined with smooth streamlined contouring allows passage of large solids minimizing the potential for clogging.

K. 100% FLOW AREA

For improved flow characteristics and lower head loss, the Val-Matic SURGEBUSTER!® Swing Check Valve provides 100% unrestricted flow area.

Pumping applications with high head, surge tanks, or multiple pumps, have long proved a challenge to system operators trying to minimize line surges resulting from slamming check valves.

Only one real cause exists for slamming check valves -- reverse flow. The impact of the reverse flow is direct and proportional, the faster the reverse flow, the more violent the slam. If reverse flow through the check valve is allowed to develop, the reverse flow will slam the disc into the seat and create a loud water hammer or surge.

Now system operators have the solution...the SURGEBUSTER®! The newest member of the Swing-Flex® family.

The SURGEBUSTER® is a swing check valve that fully meets ANSI/AWWA C508. But here is where the similarities to traditional swing check valves end.

The SURGEBUSTER® achieves rapid closure through a short disc stroke of 35° and adjustable Disc Accelerator™. The short disc stroke is less than half the typical 80° to 90° stroke of a conventional swing check valve. It is achieved by placing the valve seat on a 45° angle while maintaining a full flow area equal to the mating pipe (Figures 1 & 2.)

The Disc Accelerator™ is a precision formed

stainless steel mechanism that closes the valve disc rapidly thus avoiding slamming by flow reversal and yet allowing the disc to be stabilized under flow conditions. The accelerator is fully enclosed within the valve and completely out of the flow path (Figures 1 & 2).

VAL-MATIC SURGEBUSTER® VALVE

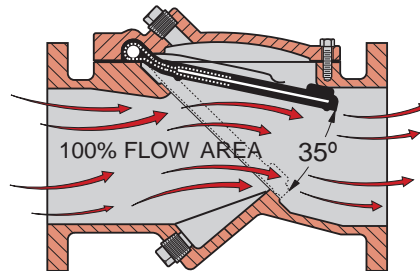

Figure 1

CONVENTIONAL SWING CHECK VALVE

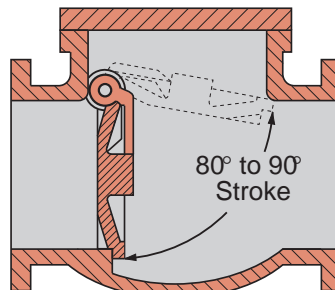

Figure 2

Traditional swing check valves use outside levers with weights or springs in an attempt to reduce slam. By doing so, they pull the disc down into the flow and reduce the length of the disc stroke so that it closes faster.

Unfortunately, while outside levers and weights help solve one problem, they create two others. Increased headloss and maintenance are inevitable with traditional swing check valves. Pulling the disc down into the flow creates a blockage in the line and causes tremendous headloss and turbulence. With the disc oscillating in the flow, the shaft, bearings, and shaft seal are all subjected to severe wear and reduced service life.

In many applications, even this approach has proven ineffective and led to the inclusion of an air cushion cylinder. The air cushion is attached to the weight or spring powered lever that is pulling the disc down. The traditional air cushion on the other hand is working in reverse by slowing the disc through its full stroke and allowing reverse flow to build. The end result, especially on fast flow reversal systems, is a slamming check valve and water hammer.

The SURGEBUSTER® with its short 35-degree stroke and Disc Accelerator™ provide fast closure thereby preventing slam and the resultant surge without obstructing flow or the need for maintenance.

Val-Matic is so confident in the SURGEBUSTER'S non-slam performance that we guarantee* the valve will outperform any air cushion swing check valve with weight and lever.

* Warranty details available upon request.



Optional Accessories

RUBBER LINING -- Unlike conventional swing check valves, the SURGEBUSTER® Check Valve is designed to accept synthetic or natural rubber lining. Body lining coupled with synthetic *Memory-Flex*™ discs makes the SURGEBUSTER® ideally suited for systems containing abrasive or corrosive fluids.

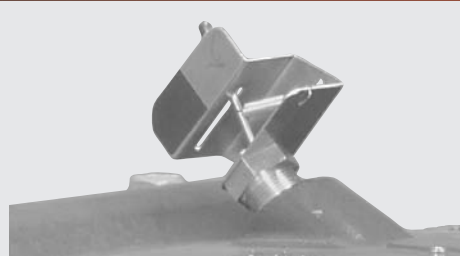
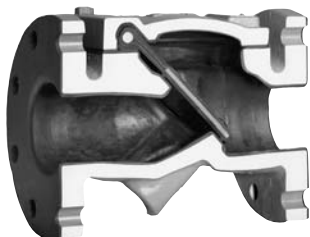

DISC POSITION INDICATOR -- The cover mounted disc position indicator provides clear indication of the valve's disc position. A SCADA compatible limit switch can also be provided. Both can be provided at the time of valve purchase or for field installation at a later date.

BACKFLOW ACTUATOR -- Available for use when manual backflow operation is required. Most commonly used for priming pumps, back flushing, draining lines, and system testing. The Val-Matic Backflow Actuator can be provided at the time of valve purchase or for field installation at a later date.

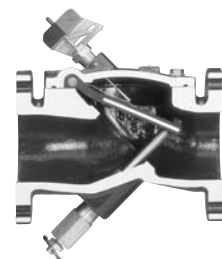



Head Loss Chart

HEAD LOSS IN FEET OF WATER

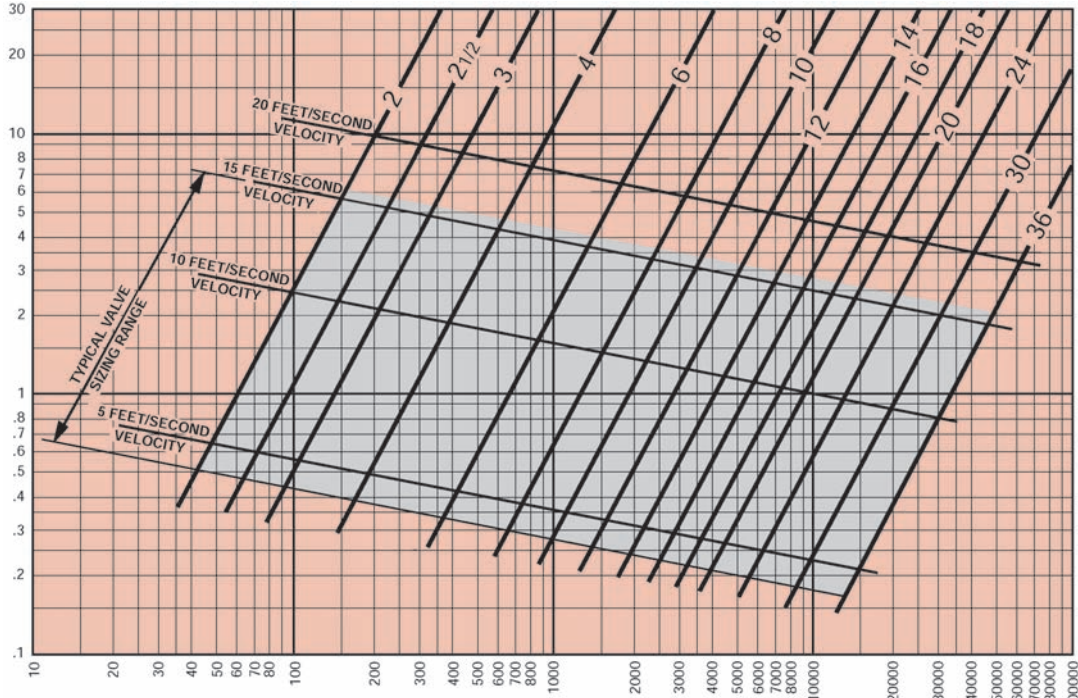

FLOW OF WATER IN GALLONS PER MINUTE

Consult factory for Digester Gas Service

Flow Tests performed by the Utah Water Research Laboratory of Utah State University.



Installation Dimensions and Construction

VALVE SIZE	MODEL #	A	E	F1	F2	H	J	K	L
2	502A	8	2	N/A	3 3/8	-1/2	6 3/4	7/8	1 1/2
2 1/2	525A	8 1/2	2 1/2	N/A	3 3/8	-1/2	7	5/8	1 1/2
3	503A	9 1/2	3	7 5/8	5 1/8	-3/8	7 1/2	3/4	1 3/4
4	504A	11 1/2	4	8 1/4	5 3/4	1 1/2	7 1/4	2 5/8	2 5/8
6	506A	15	6	9 3/8	6 7/8	2	12	6 1/4	3 1/4
8	508A	19 1/2	8	11	8 3/8	2	15 3/4	7 1/2	4 1/4
10	510A	24 1/2	10	13 3/8	10 3/4	4	20 3/8	8	5 1/4
12	512A	27 1/2	12	15	12 1/2	3 1/2	22 1/2	10	6 1/2
14	514A	31	14	17 5/8	13	4	26 1/4	11 5/8	7 1/2
16	516A	32	16	18 7/8	14 1/4	4 5/8	30	13 1/4	8 5/8
18	518A	36	18	20	15 1/4	5 1/4	33 3/4	15	9 3/4
20	520A	40	20	21 3/8	16 7/8	5 7/8	37 1/2	16 5/8	10 7/8
24	524A	48	24	23 7/8	19 1/4	7	45	20	13
30	530	56	30	27 5/8	23	-5/8	41 1/4	12	6
36	536	63	36	31	27 3/8	-6 1/8	43 1/2	8	6

Dimensions "L" and "K" represent the clearance required to remove backflow actuator.

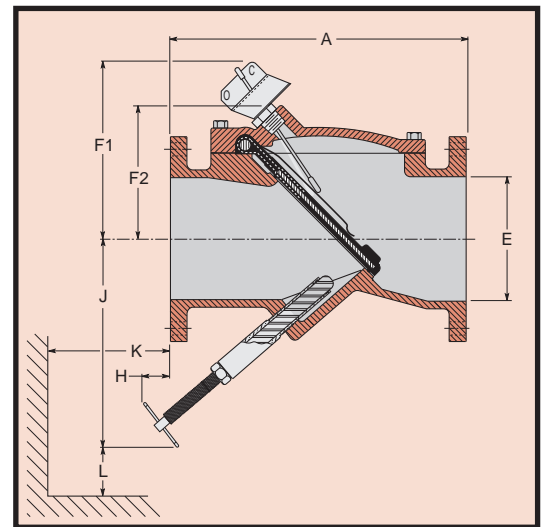

*Dimension "E" represents nominal valve size.

Note: Flanged ends conform to ANSI B16.1 Class 125.

MATERIALS OF CONSTRUCTION			
Component	Standard	Optional	
Body and Cover	Ductile Iron ASTM A536 Grade 65-45-12	Stainless Steel, Bronze	
Disc	Buna-N (NBR), ASTM D2000-BG	Viton (FKM), ASTM D2000-HK	
Disc Accelerator	TYPE 302 Stainless Steel	N/A	
Coatings	Interior	Fusion Bonded Epoxy*	Rubber Lining
	Exterior	Fusion Bonded Epoxy*	Consult Factory

Consult factory for additional material and coating options.

*ANSI/NSF 61 Certifications

ANSI MAXIMUM PRESSURE-TEMPERATURE RATING		
Maximum Non-Shock Working Pressure (P.S.I.) ANSI Class 125		
Temperature °F	2" - 24"	30" - 36"
100°	250	150
150°		
200°	235	135
Hydrostatic Test Pressures	375	230

For higher temperatures consult factory.



SURGEBUSTER® Swing Check Valve Specification

1.1 This specification is intended to cover the design, manufacture, and testing of 2 in. (50 mm) through 36 in. (900 mm) SURGEBUSTER Swing Check Valves suitable for cold working pressures of 250 psig (1025 kPa) (150 psig for 30 in. and larger) in water, wastewater, abrasive and slurry service.

1.2 The Check Valve shall be of the full body flanged type, with a full size domed access cover and only two moving parts, the flexible disc and the disc accelerator.

Standards and Approvals

2.1 The valves shall be designed, manufactured and tested in accordance with American Water Works Association Standard ANSI/AWWA C508.

Connections

3.1 Valves shall be provided with flanges in accordance with ANSI B16.1, Class 125.

Design

4.1 The valve body shall have full flow equal to nominal pipe diameter at all points through the valve. The 4 in. (350mm) valve shall be capable of passing a 3 in. (75 mm) sphere. The seating surface shall be on a 45 degree angle to minimize disc travel. A threaded port with pipe plug shall be provided on the bottom of the valve to allow for field installation of a backflow actuator without special tools or removing the valve from the line.

4.2 The top access port shall be full size, allowing removal of the disc without removing the valve from the line. The access cover shall be domed in shape to provide flushing action over the disc for operation in lines containing high solids content. A threaded port with pipe plug shall be provided in the access cover to allow for field installation of a mechanical, disc position indicator.

4.3 The disc shall be of one-piece construction, precision molded with an integral or-ring type sealing surface, and contain alloy steel and nylon reinforcement in the flexible hinge area. The flex portion of the disc shall be warranted for twenty-five years. Non-Slam closing characteristics shall be provided through a short 35 degree disc stroke and a disc accelerator.

4.4 The disc accelerator shall be of one piece construction and provide rapid closure of the valve in high head applications. The disc accelerator shall be enclosed within the valve and shall be field adjustable and replaceable without removal of the valve from the line. The disc accelerator shall be securely held in place by being captured between the cover and disc. It shall be formed with a large radius to allow smooth movement over the disc surface.

4.5 The valve disc shall be cycle tested 1,000,000 times in accordance with ANSI/AWWA C508 and show no signs of wear, cracking, or distortion to the valve disc or seat and shall remain drop tight at both high and low pressures. The test results shall be independently certified.

Materials

5.1 The valve body and cover shall be constructed of ASTM A536 Grade 65-45-12 ductile iron. Optional body materials include ASTM A-351 Grade CF8M, Stainless Steel (sizes 3" through 8")

5.2 The disc shall be precision molded Buna-N (NBR), ASTM D2000-BG. Optional disc material includes Viton.

5.3 The disc accelerator shall be type 302 stainless steel.

Options

6.1 A screw-type backflow actuator shall be provided when specified to allow open-

ing of the valve during no-flow conditions. Buna-N seals shall be used to seal the stainless steel stem in a bronze bushing. The backflow device shall be of the rising-stem type to indicate position. A stainless steel T-handle shall be provided for ease of operation.

6.2 A mechanical indicator shall be provided when specified to provide disc position indication on valves 4" and larger. The indicator shall have continuous contact with the disc under all operating conditions to assure accurate disc position indication.

6.3 A pre-wired limit switch will be provided when specified to indicate open/closed position to a remote location. The mechanical type limit switch shall be activated by the external position indicator. The switch shall be rated for NEMA 4, 6 or 6P and shall have U.L. rated 5 amp, 125 or 250 VAC contacts.

Manufacture

7.1 The manufacturer shall demonstrate a minimum of five (5) years experience in the manufacture of resilient, resilient hinge check valves.

7.2 All valves shall be hydrostatically tested and seat tested to demonstrate zero leakage. When requested, the manufacturer shall provide test certificates, dimensional drawings, parts list drawings, and operation and maintenance manuals.

7.3 The exterior and interior of the valve shall be coated with an NSF approved fusion bonded epoxy coating.

7.4 SURGEBUSTER Swing Check Valves shall be Series #7200 as manufactured by Val-Matic Valve & Mfg. Corporation, Elmhurst, IL, USA or approved equal.



Dynamic Testing of Check Valves

DYNAMIC TESTING OF CHECK VALVES

SURGEBUSTER® and Air Cushioned Swing Check Valves were flow tested under identical dynamic conditions and the downstream pressure plotted as shown in Figures 1 and 2. The valves were installed on the discharge of a four-inch 20 HP water pump and connected to a hydro-pneumatic tank charged to 30 psig. After pump shutdown, the water flow would rapidly reverse in about 1/2 second and cause rapid valve closure.

The Air Cushioned Swing Check Valve was equipped with a lever, weight, and air cushion with flow control valve. Despite an operating velocity over 8 feet per second, the Cushioned Swing Check Valve traveled only 15 degrees or about 25%

open. Partially open check valves are common and can cause excessive headloss and energy consumption. Adjustments to the air cushion revealed that any control setting of the cushion, slowed down the valve closure, and magnified the valve slam. In Figure 1, the valve closed with a loud slam and produced an upsurge in the downstream piping of 150 psi over the static pressure.

The SURGEBUSTER® was operated under the same flow conditions and was found to open 35 degrees or 100% open. In Figure 2, after pump shutdown the SURGEBUSTER® closed with a negligible slam and produced an upsurge in the downstream piping of only 25 psi over the static pressure.

The dynamic tests demonstrate that the SURGEBUSTER® can reduce check valve slam up to 80% when compared to conventional swing check valves. Numerous field installations with vertical lines, multiple pumps, and high pump discharge head all demonstrated the same result. The SURGEBUSTER® provides non-slam operation with reduced headloss and maintenance.

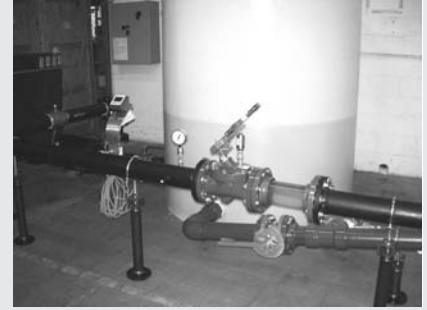

Figure 1

The air cushioned swing check valve closed with a loud slam producing a 150 psi surge with optimum cushion adjustment.

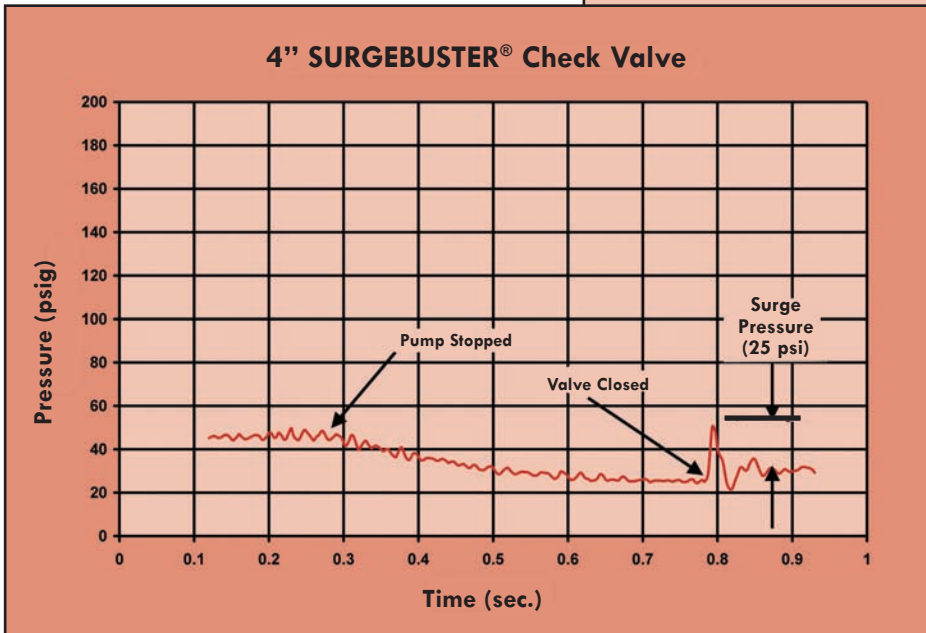
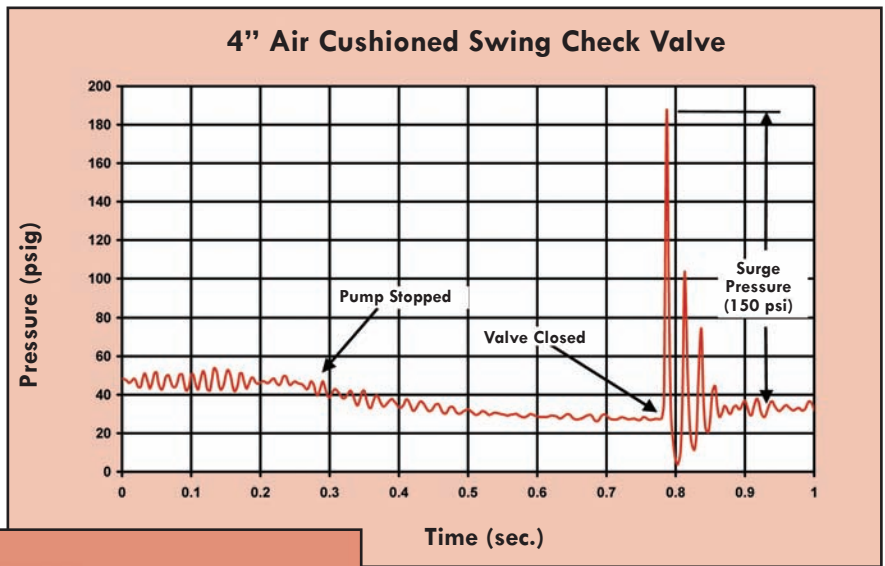
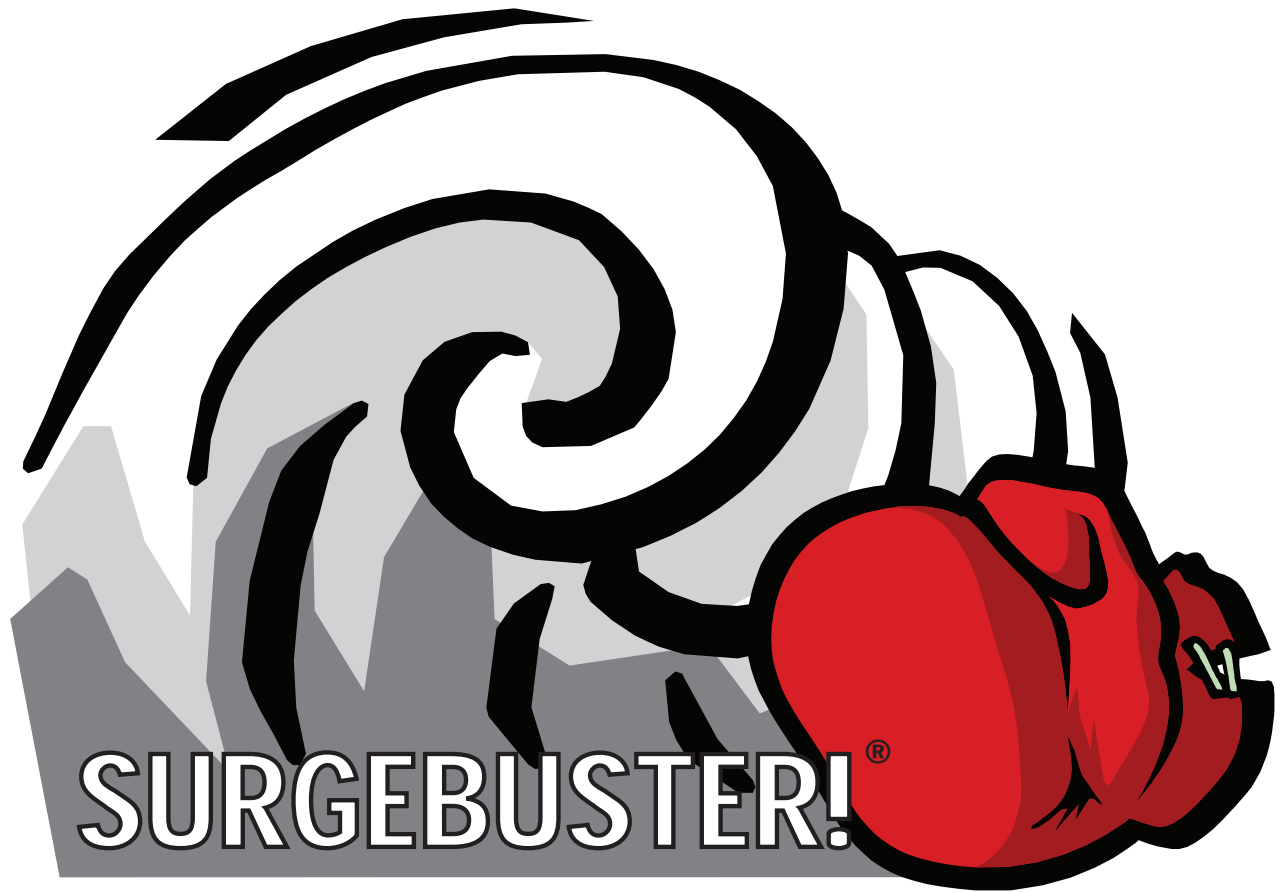

Figure 2

The SURGEBUSTER® closed quietly producing only a 25 psi surge pressure, 80% less than the conventional air cushioned swing check valve.



A member of the Swing-Flex® Family

Val-Matic is so confident in the SURGEBUSTER's non-slam performance that we guarantee* the valve will outperform any air cushion swing check valve with weight and lever.

***Warranty details available upon request.**



Make the change to **QUALITY!** Specify **VAL-MATIC®**

Val-Matic's quality of design and meticulous workmanship has set the standards by which all others are measured. Quality design features such as Type 316 stainless steel trim as standard on Air Release, Air/Vacuum and Combination Air Valves...combined resilient/metal to metal seating for Silent Check® Valves...stabilized components that provide extended life of the Dual Disc® Check Valves...high strength and wear resistant aluminum bronze trim as standard for Tilted Disc® Check valves...unrestricted full flow area through Swing-Flex® Check Valves...heavy duty stainless steel screened inlet on Sure Seal® Foot Valves...a Cam-Centric®

Plug Valve with more requested features than any other eccentric plug valve, and the American-BFV® Butterfly Valve that provides a field replaceable seat without the need for special tools. These features coupled with our attention to detail put Val-Matic valves in a class by themselves.

Val-Matic is totally committed to providing the highest quality valves and outstanding service to our customers. Complete customer satisfaction is our goal.

VAL-MATIC®

VAL-MATIC VALVE AND MANUFACTURING CORP.

905 RIVERSIDE DRIVE • ELMHURST, IL 60126

630/941-7600 • FAX: 630/941-8042

www.valmatic.com

valves@valmatic.com