

VAL-MATIC®

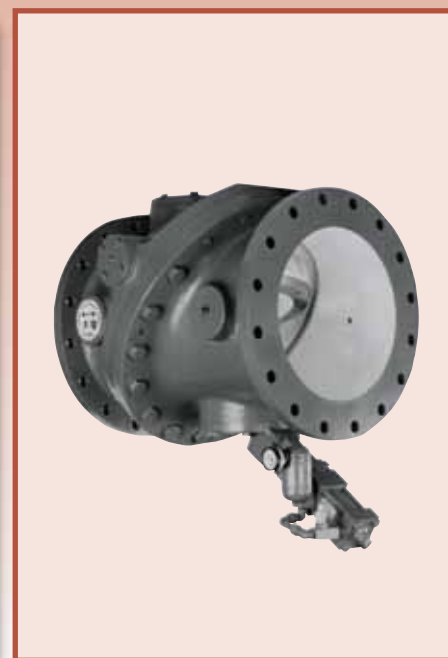

HIGH PERFORMANCE

- ...NON-SLAM CLOSURE
- ...ENERGY EFFICIENT
- ...WEAR RESISTANCE
- ...LEAK TIGHT SEATING
- ...VERSATILITY OF OPERATION



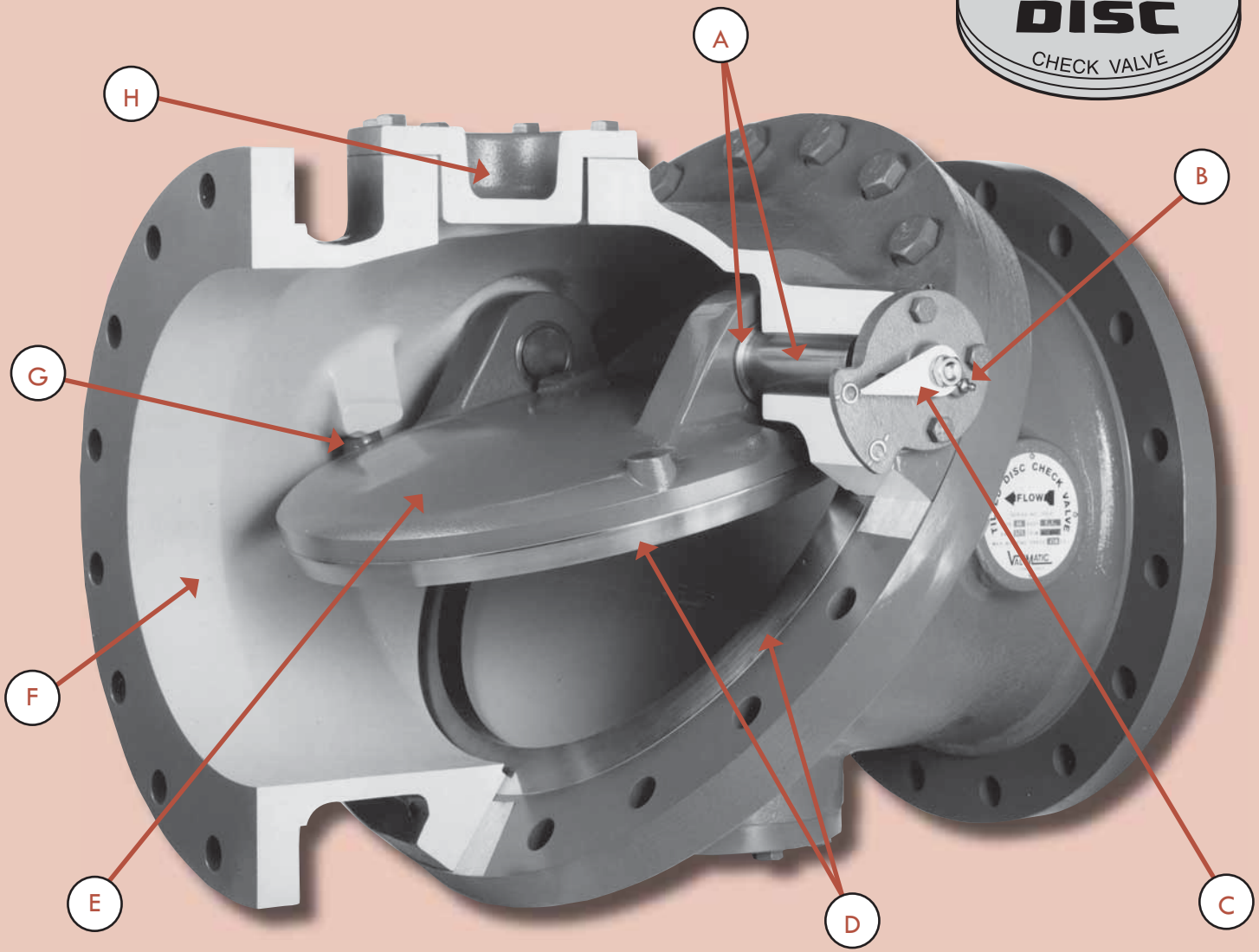

A. PIVOT PINS AND BUSHINGS

Maximum strength is achieved by utilizing large diameter pins constructed of high tensile materials. These materials provide superior wear and gall resistance as a result of their high Brinnell Hardness (BHN) together with a selected difference in hardness between mating parts.

B. GREASE FITTINGS

Although lubrication is not essential to the operation of the Tilted Disc Check Valve, grease fittings are used to assure even longer life and greater dependability.

C. DISC POSITION INDICATOR

A unique connection provides an accurate indication of the disc position at all times. Standard on sizes 6" and larger.

D. DISC AND SEAT RINGS

Superior wear and gall resistance are achieved through the use of materials having a high Brinnell Hardness (BHN) together with a selected difference in hardness between the disc and seat rings. Leak tight seating is attained at all working pressures by utilizing a 20° seating angle which provides excellent sealing characteristics. This angle, by its nature, is self releasing and therefore prevents any binding of the disc and seat.

E. DISC

A hydrodynamically balanced design provides minimum resistance to flow, lift and stabilization, and excellent flow characteristics.

F. BODY

Ultra low head loss is the result of streamlined body contouring and a flow area through the seat which is a minimum of 40% greater than nominal pipe size.

G. STOP LUGS

Positive stops are accurately positioned to prevent disc flutter at both high and low flow velocities, while maintaining ultra low head loss characteristics.

H. INSPECTION PORTS

Ports allow access to the upstream and downstream sides of the seat, and also serve as mounting ports for optional dashpots.

APPLICATIONS

The Tilted Disc Check Valve is the premier check valve in the Val-Matic family. It offers unrivaled versatility and reliability while providing a significant cost savings over the life of the valve. While some valves are ideally suited to a specific application or orientation, the Tilted Disc is appropriate in any number of installation configurations.

In a single pump system, or a system where only one pump is operating at a time, Tilted Disc Check Valves are commonly used with both centrifugal and turbine pumps where flow rates are in the range of 4-20 ft/sec and pressures are up to 400 PSI.

Multiple pump systems, systems set up to reduce slamming, and systems set up to provide high capacity are ideal applications for the Tilted Disc. Depending on the system pressure, multiple pumps or parallel pumps can cause a rapid flow reversal upon system shut-down and the flow rate can vary constantly. The Tilted Disc is offered with optional top or bottom mounted oil dashpots to aid in disc closure in multiple pump systems even after a power failure.

In closed tank surge applications, such as a hydropneumatic tank, it is critical to have a check valve close rapidly to prevent reverse flow through the pump after pump stoppage. The Tilted Disc Check Valve with bottom mounted dashpot is the preferred solution in this application, as it allows for space constraints, and because of the dashpot, allows the valve to close rapidly and still prevent slamming.

Val-Matic Tilted Disc Check Valves are used worldwide to offer superior service and features in any number of applications and environments. Further information on specific application parameters and the benefits of the Tilted Disc Check Valve are available online at www.valmatic.com including the White Paper AEG-301.

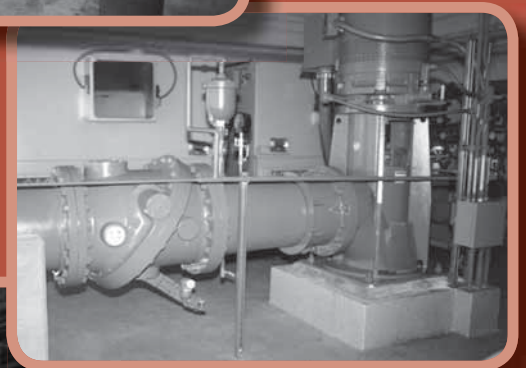

ENERGY EFFICIENT PLUS...

THE VAL-MATIC TILTED DISC CHECK VALVE provides energy efficient operation while easily handling the most severe and demanding applications with features such as non-slam closure, wear resistance, leak tight seating, and versatility of operation. This high performance check valve performs well in any number of operating conditions and has the added benefit of extremely low headloss characteristics.

ENERGY EFFICIENT:

The Tilted Disc conserves energy and provides the lowest operating cost because it provides some of the lowest pressure loss characteristics of any check valve available today. This ultra low head loss is the result of a streamlined body contouring and a hydrodynamically designed disc, in combination with a flow area through the seat that is 40% greater than nominal pipe size. (Figure 1)

The energy savings realized by using a 30" Tilted Disc Check Valve instead of a traditional swing check valve would pay for the valve in approximately six years. From that point forward the owner will continue to realize a savings in energy costs of over \$3,600 a year. (see page 10 for details)

NON-SLAM CLOSING:

The non-slam closing characteristics of the Tilted Disc are achieved by utilizing a short disc stroke, unique disc counteraction, and fixed pivot pins without stem packing. The short disc stroke, resulting from the angled seat design, is only 40° as compared to the approximate 80° to 90° stroke found in a conventional swing check valve. This short stroke reduces the closing time of the valve disc. The reduced closing time minimizes flow reversal and the water hammer effect normally associated with the sudden stopping of a reverse flow. (Figure 2)

The disc counteraction is the result of an offset pivot which divides the disc into approximately a one third/two thirds proportion. This allows the two thirds of flow that passes below the pivot to be counteracted by the one third that passes above the pivot. This counteraction reduces slamming by providing a self-cushioning effect not found in conventional swing-check valves. (Figure 3)

Finally, while conventional swing check valves have rotating stems with packing, the Tilted Disc Check Valve's disc rotates freely on fixed pins providing low inertia and friction to accelerate disc closure.

- ...NON-SLAM CLOSURE
- ...WEAR RESISTANCE
- ...LEAK TIGHT SEATING
- ...VERSATILITY OF OPERATION

Figure 1

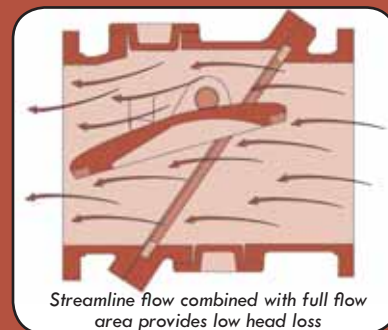

Figure 2

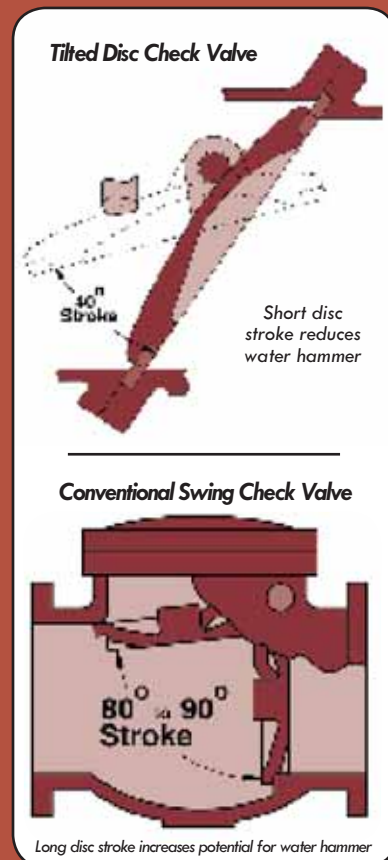
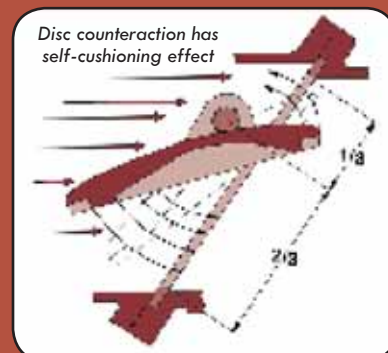

Figure 3



HIGH PERFORMANCE

WEAR RESISTANCE:

Extended valve life is the result of excellent wear resistance brought about by such design features as *disc stabilization* and *lift and tilt disc action* along with a meticulous selection of materials of construction for those components in working contact.

Our hydrodynamic design provides lift and disc stabilization during flow. Tests conducted by an independent laboratory showed the disc to be extremely stable during both low and high flow conditions thereby minimizing wear associated with disc flutter. (Figure 4)

The disc pivot is eccentrically located in a manner that allows the disc to lift and tilt into and out of the body seat without sliding or binding. This unique tilting action reduces the disc to seat contact and its resulting wear. (Figure 5)

High wear resistant materials are provided as standard for all contact parts such as pivot and seating surfaces.

LEAK TIGHT SEATING:

Leak tight is achieved by utilizing a 20° seating angle and maintaining a slight pivot clearance. The 20° seating angle offers optimum taper-sealing qualities while also having non-binding, self-releasing characteristics. The small amount of pivot clearance allows the disc to close and seal on the body seat without pivot interference. (Figure 6)

To demonstrate the excellent seating and wear resistant qualities of the Tilted Disc Check Valve, an extensive cycle test was conducted and witnessed by an independent engineering consulting firm. Results of that test show that even after more than 100,000 cycles, the Val-Matic Tilted Disc Check Valve had less than 10% of the allowable leakage for NEW valves as called for in the testing sections of AWWA and MSS specifications for valves. Copies of the test results are available upon request.

OPTIONAL EQUIPMENT

In addition to the many improved features and operating characteristics found in the basic Tilted Disc that separate it from conventional swing-check valves, the Val-Matic Tilted Disc Check Valve offers unrivaled versatility of operation with the following optional equipment.

Limit Switch

SCADA compatible limit switches can be utilized with the disc position indicator for remote panel read outs and/or secondary system operations. Switches can be provided to indicate the fully open, fully closed, or combination of both valve positions. (Figure 7)

Disc By-Pass

By-Pass bosses are provided upstream and downstream of the valve disc. When specified, these bosses are drilled and fitted with the necessary piping and shut-off valves to create a manual or automatic disc by-pass.

Valve Size	2-4"	6"	8"	10"	12"	14"	16"	18"
By-Pass Size	N/A	1.5"	1.5"	2"	2"	2"	3"	3"
Valve Size	20"	24"	30"	36"	42"	48"	54"	60"
By-Pass Size	3"	3"	4"	6"	6"	6"	8"	8"

Metric dimensions are available on www.valmatic.com.

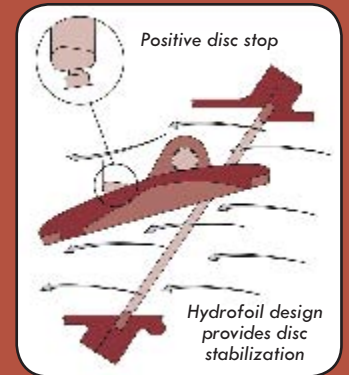

Figure 4

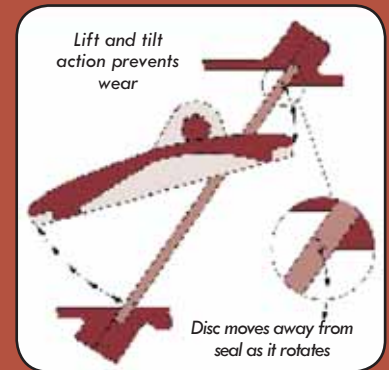

Figure 5

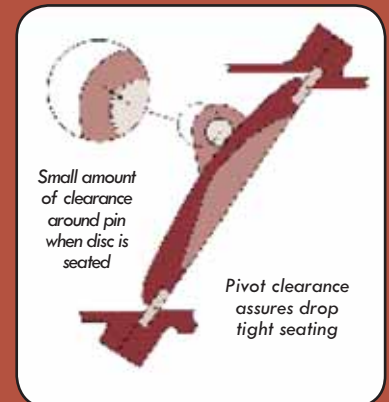

Figure 6

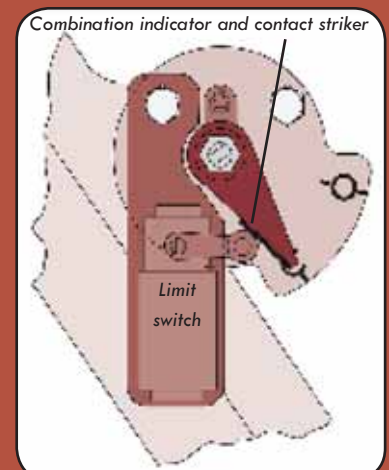

Figure 7

OPTIONAL DASHPOTS

BOTTOM MOUNTED OIL DASHPOT

Bottom Mounted Oil Dashpots (BMOD) further reduce the water hammer potential associated with systems having rapid flow reversal characteristics. These critical conditions are normally found in piping systems which have high shut-off heads, and/or use pressure tanks or surge tanks. BMOD's are not directly connected to the disc, and therefore allow the valve disc to open freely without restriction and close freely for 90% of its travel, for the remainder of its travel, the disc will contact the dashpot snubber rod. Once contact is made, the speed of closure for the final 10% of disc movement can be adjusted to a rate best suited for the application.

The BMOD is a self-contained oil operated system which has an air gap between the system media and the dashpot cylinder. This air gap positively prevents any pressurized hydraulic fluid from entering the valve housing and contaminating the system media. The BMOD is installed in the bottom inspection port of the Tilted Disc and is available on valve sizes 6" and larger. When necessary, the unit can also be field installed.



Tilted Disc Check Valve with Bottom Mounted Oil Dashpot

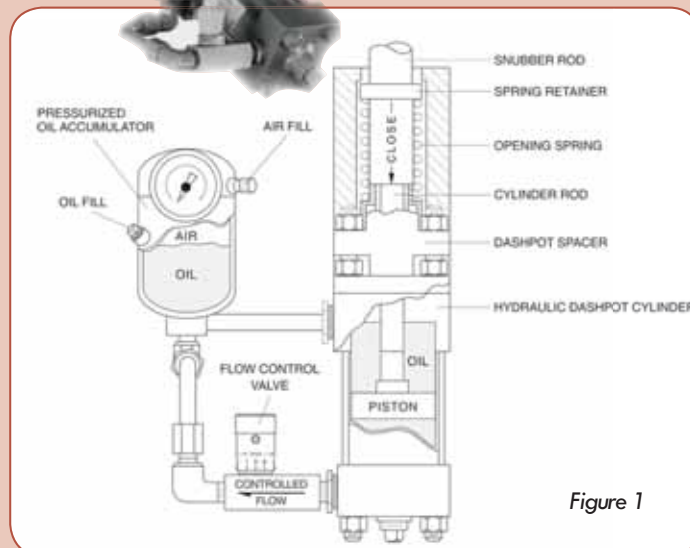
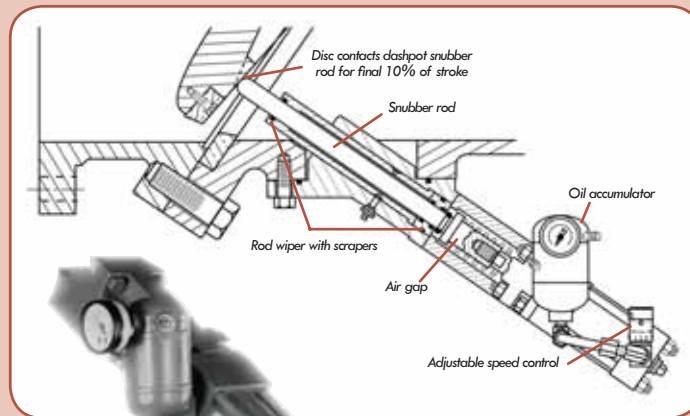

Figure 1

SEQUENCE OF OPERATION

The last 10% of closing of the check valve can be controlled by an optional hydraulic dashpot cylinder to prevent slamming where rapid flow reversals are expected. (Figure 1) The cylinder rod pushes against a snubber rod which in turn makes contact with the valve disc. Both sides of the hydraulic cylinder are connected to a pressurized oil accumulator which is held at the maximum line pressure plus 50 psi. Because the cylinder piston has a greater pressure area opposite the rod end, the air pressure in the accumulator will tend to extend the rod. The opening spring is also designed to extend the rod in case air pressure is lost.

OPENING STROKE:

When the water system pump is started, the water pressure will force the check valve disc open. The air pressure in the accumulator and the spring will extend the cylinder and snubber rods into the valve port.

CLOSING STROKE:

When the water system pump is stopped, the weight of the disc and reverse flow of water will force the check valve disc closed thereby striking the snubber rod. The snubber rod will push on the cylinder rod in the direction shown and force oil through the adjustable flow control valve. The flow control valve will control the speed of closure for the last 10% of valve travel in typically 1 to 5 seconds.

OPTIONAL DASHPOTS, CONT.

TOP MOUNTED OIL DASHPOT

The Top Mounted Oil Dashpot (TMOD) is directly connected to the disc and provides full control of the valve disc to further reduce the potential for surges and water hammer.

The unit provides single stage adjustable speed control of the disc's travel to the open position thereby reducing system pressure surges upon pump start-up. Two stage control is provided during valve closure, reducing the water hammer and surges associated with rapid flow reversal systems. The first stage controls 90% of the disc closure, while the second stage controls the final, critical 10% of closure.

All controls are independent of each other and can be field adjusted to best suit the application. For example, the first stage of closing can be at a slower rate than the opening rate, with the final 10% of closure at even a slower rate. Tilted Disc Check Valves with dashpots are not intended to replace system surge control equipment, but to further minimize the slamming and water hammer associated with conventional swing check valves. The TMOD is also a self-contained oil operated system which has an air gap spacer between the system media and the dashpot. The air gap prevents any possibility of the hydraulic fluid from entering the system and contaminating the line media. TMOD are available for all valve sizes 6" and larger. A Quick Change Coupling is provided to facilitate removal of the cylinder should it be necessary without removal of the valve from the line.

Tilted Disc Check Valve with Top Mounted Oil Dashpot

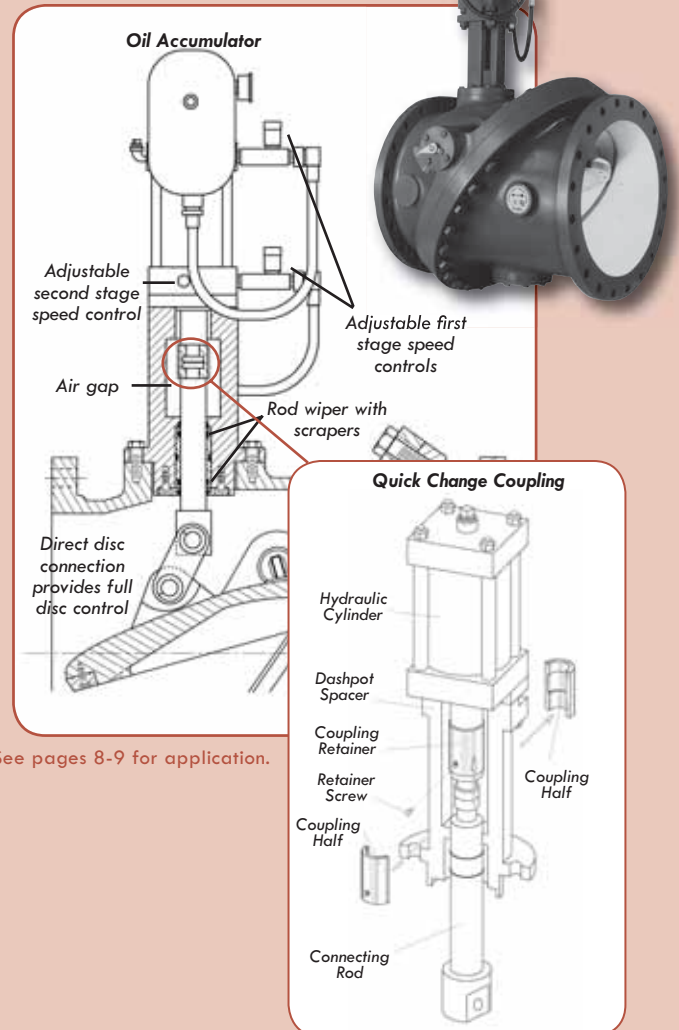

See pages 8-9 for application.

SEQUENCE OF OPERATION

OPENING STROKE:

When the water system pump is started, the water column will force the check valve disc open thereby pushing the cylinder rod upward. (Figure 2) The oil over the cylinder piston will become pressurized and flow through the open flow control valve and into the pressurized oil accumulator typically in 5-30 sec. Oil will also be drawn into the lower portion of the cylinder through the check valve portion of the close flow control valve and the vented oil accumulator.

CLOSING STROKE:

When the water system pump is stopped, the weight of the disc and reverse flow of the water will force the check valve disc closed thereby pulling the cylinder rod down. The oil under the cylinder piston will become pressurized and flow through the close flow control valve and into the vented oil accumulator typically in 5-30 sec. Oil will also flow into the top of the cylinder from the pressurized oil accumulator through the check portion of the open flow control valve. The pressurized oil accumulator is maintained at 20% of the water line pressure to assist in valve closure.

FINAL 10% OF CLOSURE:

During the last 10% of closure, the larger diameter portion of the cylinder rod enters a cushion chamber in the lower head of the dashpot cylinder. The speed of closure during the last 10% of closure can be controlled further using the cushion control adjustment screw located on the cylinder head, typically 1 to 5 seconds.

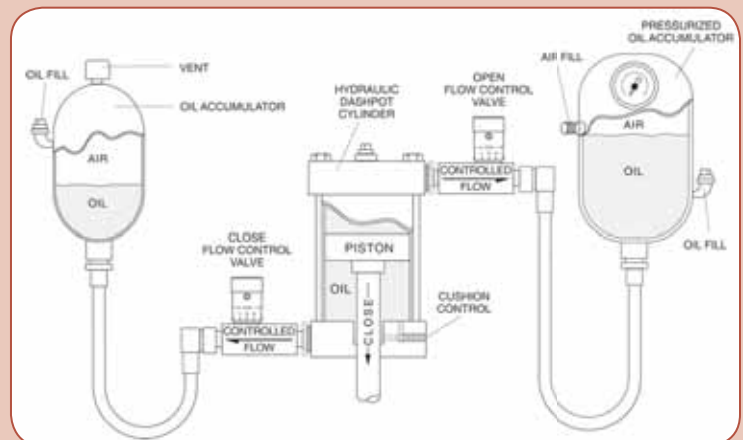

Figure 2

VALVE SELECTION

THE TILTED DISC CHECK VALVE IS AVAILABLE IN THREE CONFIGURATIONS:

- Basic
- Bottom Mounted Oil Dashpot
- Top Mounted Oil Dashpot

It is important to note that the dashpot configurations include high pressure oil cylinders and full rated disc connections. With oil dashpots, the disc is rigidly controlled as opposed to an air cushion which only produces a minimal dampening effect.

To select the proper valve configuration, several criteria must be considered. The number of pumps and the static head will effect how rapidly the water column will reverse when a pump is stopped. The type of pump control will effect the required closing characteristics of the valve. Typical types of control include on-off, soft-start, variable speed, and electrically operated control valves. The length of the piping system is used to estimate surges from changes in flow velocity. The type of surge relief system dictates the required closing time for the valve. Surge tanks require a quick-closing valve to prevent the loss of stored water back through the pump. The criteria listed above are used to select the best valve configuration as follows.

1. BASIC VALVE

The basic valve features a short stroke angle of 40° which provides rapid disc closure in less than 1/2 second. This feature will provide non-slam closure in low service pumping applications. Basic valves are typically used when the static head is less than 100 feet in single or multiple pump application. A common application is the filter backwash pumps in a water treatment plant.

2. BOTTOM MOUNTED OIL DASHPOT

Dashpots are used on high service pumping applications where there is a propensity for rapid flow reversal. The dashpot consists of a hydraulic cylinder and snubber rod which contacts the disc during closing. The dashpot controls the last 10% of valve closure to reduce water hammer and prevent slamming of the disc.

The valve is effective on shorter length systems with static heads up to the valve rating. The dashpot is also used on longer systems where rapid flow reversal occurs due to the use of surge tanks or in multiple pump systems. The dashpot is field adjustable and typically set to control the last 10% of closure in 1-5 seconds. A greater closure time may produce excessive reverse flow through the pump.

3. TOP MOUNTED OIL DASHPOT

The top mounted oil dashpot controls both the full opening and full closing stroke of the valve. Also, the last 10% of travel of valve closure is independently controlled by an adjustable hydraulic cylinder cushion. With the top mounted oil dashpot, the disc is mechanically linked to a hydraulic cylinder and linkage is designed to withstand the full thrust of the disc when subjected to line pressure.

Valves equipped with top mounted oil dashpots have been used in extreme service applications up to the full flow and pressure rating of the valve. When there is insufficient space to provide a straight run of pipe between the pump and the valve, the top mounted dashpot will control the disc movement and prolong the life of the valve.

The opening and closing strokes are field adjustable in the 5-30 second range. A greater closure time may produce excessive reverse flow through the pump. The final 10% of closure is adjustable in the 1-5 second range to prevent slam.

By setting the valve opening time to 20 seconds, the system flow rate will rise to 50% in about 2 seconds which equates to the critical time period of a system 3,000 ft. in length. On longer systems, the dashpot will not have an appreciable effect on pressure surges; therefore, a surge analysis and surge equipment are recommended.

On very long systems, a power operated control valve is sometimes used. The control valve is electrically wired to the pump control and is programmed to slowly open and close to gradually change the flow rate in the system over a 30-300 second period. However, after a power outage, the control valve may not be capable of closing rapidly enough to prevent back spinning of the pump or loss of water from a surge tank. In these cases, a Tilted Disc® is often installed upstream of the control valve.

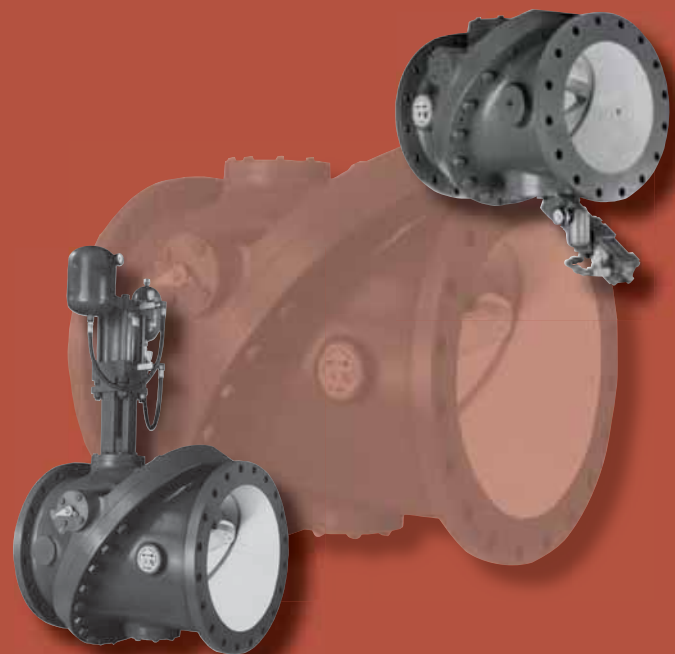

APPLICATION GRAPH

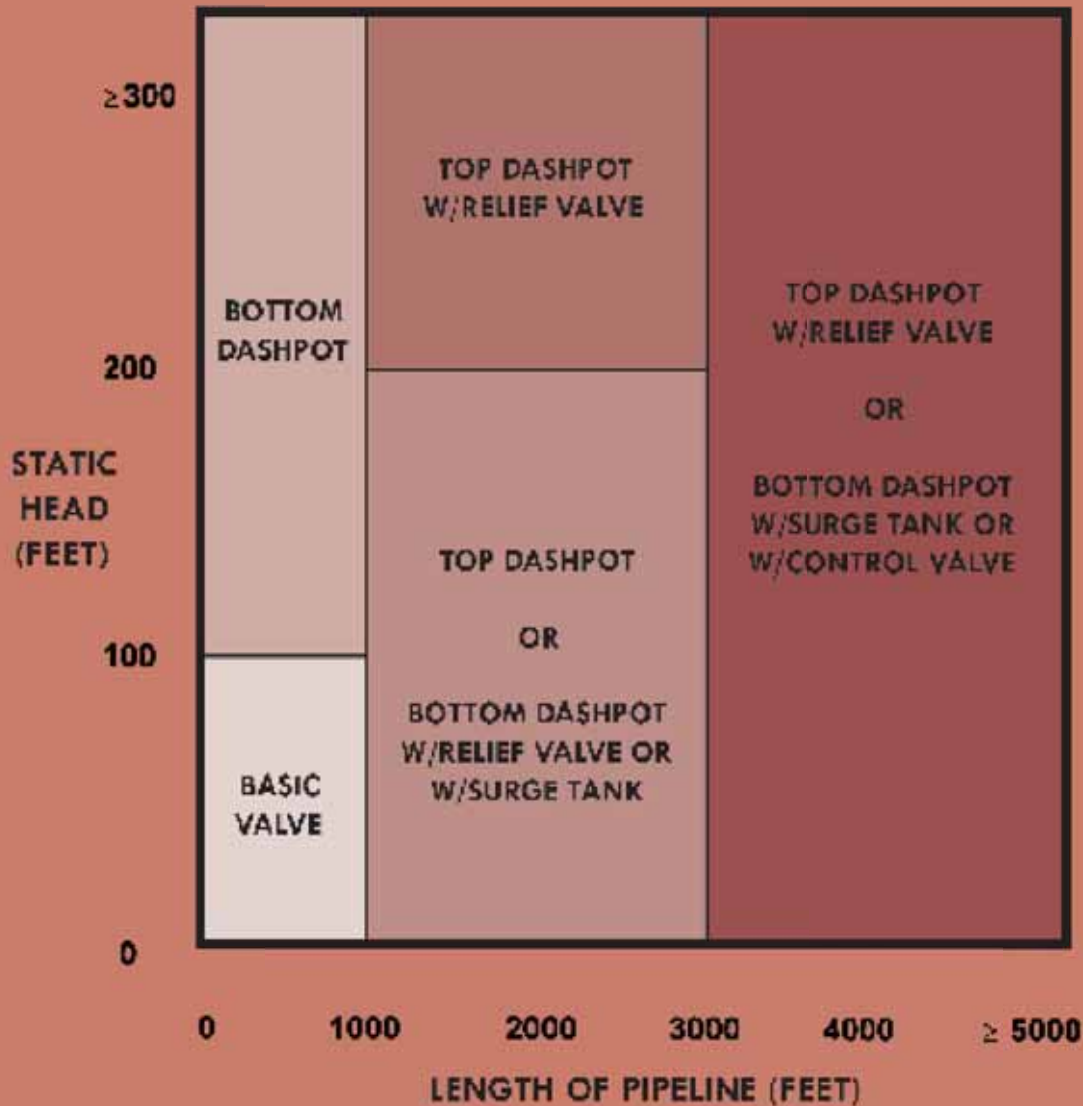

The application graph illustrates the range of use for three valve configurations: 1) basic valve, 2) bottom mounted oil dashpot, and 3) top mounted oil dashpot. For example, on a 2,500 ft. long water transmission main operating at 150 ft. of head, a Tilted Disc Check Valve with a top mounted oil dashpot would be selected. Or, if a surge relief system is provided, then the bottom mounted oil dashpot configuration may be used.

RECOMMENDATION FOR APPLICATION OF VAL-MATIC TILTED DISC® CHECK VALVES				
Type of Installation	Length	Static Head	Surge Relief System	Recommended Check Valve
Single Pump	0-1000 ft.	0-100 ft.	NONE	Basic Valve
Multiple Pump	0-1000 ft.	0-100 ft.	NONE	Basic Valve
Single/Multiple Pump	0-1000 ft.	> 100 ft.	NONE	Valve w/BMOD
Single/Multiple Pump	1000-3000 ft.	0-200 ft.	NONE	Valve w/ TMOD
Single/Multiple Pump	1000-3000 ft.	0-200 ft.	Relief Valve/Surge Tank	Valve w/ BMOD
Single/Multiple Pump	1000-3000 ft.	> 200 ft.	Relief Valve	Valve w/ TMOD
Single Pump	> 3000 ft.	> 50 ft.	Relief Valve	Valve w/ TMOD
Single Pump	> 3000 ft.	> 50 ft.	Surge Tank/Control Valve	Valve w/ BMOD

Metric dimensions are available on www.valmatic.com.

HEAD LOSS CHART

(CUBIC METERS PER HOUR)



(METERS OF WATER)



FLOW COEFFICIENTS

SIZE	Cv	K
2"	102	1.37
3"	248	1.17
4"	475	1.01
6"	1,160	0.86
8"	2,200	0.75
10"	3,600	0.69
12"	5,400	0.63
14"	7,600	0.59
16"	10,030	0.58
18"	13,200	0.54
20"	16,800	0.50
24"	25,500	0.45
30"	42,000	0.41
36"	63,000	0.38
42"	90,000	0.34
48"	119,000	0.33
54"	155,000	0.31
60"	195,000	0.30

Cv = The number of U.S. gallons/minute of 60°F water that will flow through the valve with a 1 PSI pressure drop across the valve.
K = resistance coefficient (dimensionless.)

HEADLOSS IN FEET OF WATER

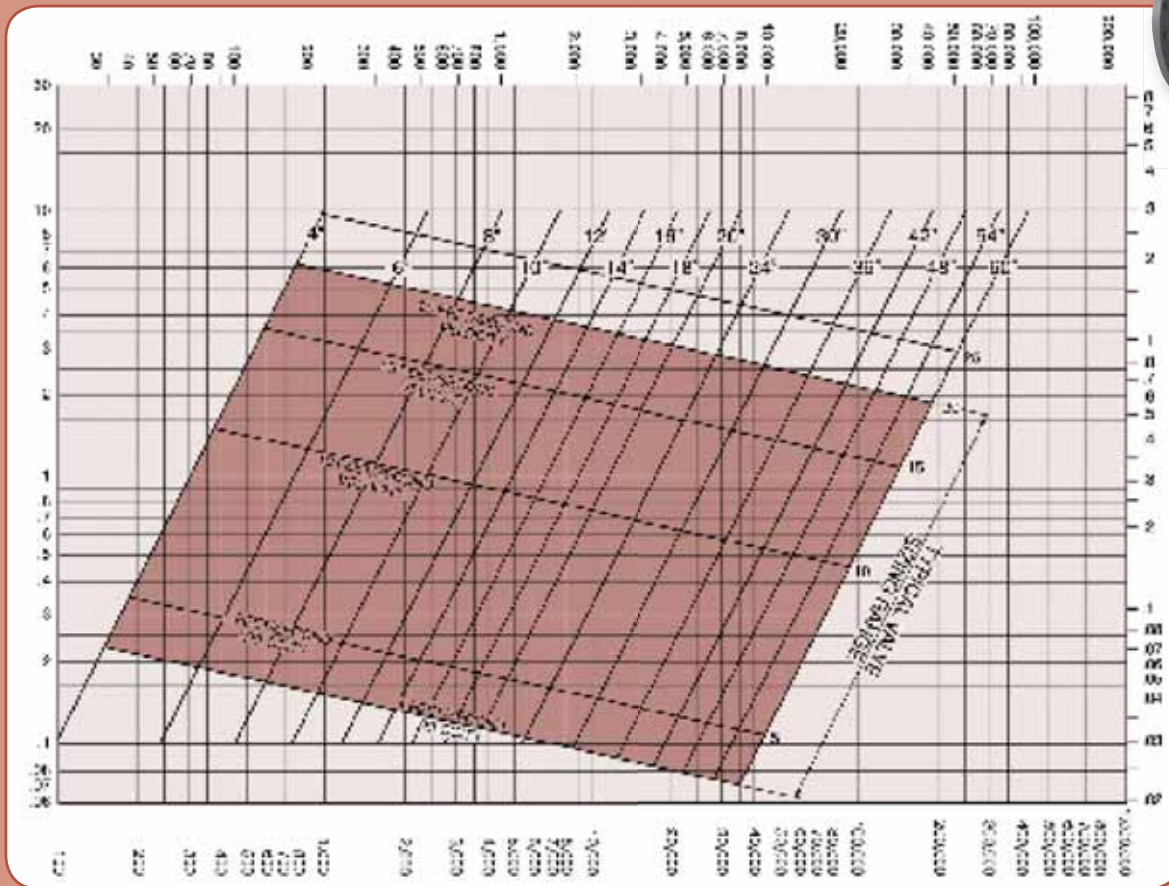

FLOW OF WATER IN GALLONS PER MINUTE

ENERGY COST SAVINGS

The Tilted Disc possesses the lowest head loss of any check valve available today, allowing the least amount of energy during system operation to be consumed. The continuous electrical energy savings that result from using the Val-Matic Tilted Disc rather than a conventional swing check valve can be calculated by using the following formula:

$$\text{ELECTRICAL COST SAVINGS PER YEAR (ECS/Y)} = \frac{\text{GPM} \times \text{HLD} \times \text{Sg} \times \text{C/Kwh} \times 1.65}{\text{PE} \times \text{ME}}$$

WHERE:	
GPM	- Pump capacity in gallons per minute
Sg	- Specific gravity (Water = 1)
PE	- Pump efficiency
ME	- Motor efficiency
C/Kwh	- Cost per kilowatt hour
HLD	- Head loss difference between Val-Matic Tilted Disc and conventional swing check valve in feet of water.

EXAMPLE:	
Size 30"	
GPM	= 20,000 † Values used are considered average and for demonstration only. Contact your local power utility, pump and motor manufacturer to establish your actual values.
Sg	= 1
C/Kwh	= .1 †
PE	= .85 †
ME	= .85 †
HLD	= .8

$$\text{ESC/Y} = \frac{20,000 \times .8 \times 1 \times .1 \times 1.65}{.85 \times .85}$$

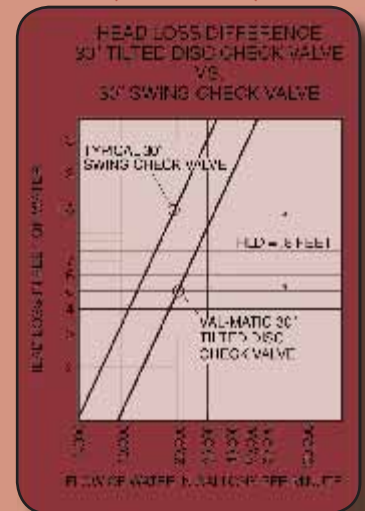

Electrical Cost Savings Per Year:

\$3,654.00

SAVINGS OVER 40YR. VALVE LIFE:

\$146,160.00

Note:

The savings are based on a system operating 24 hours per day for 365 days. For systems operating less, multiply the savings by the percentage of usage. EXAMPLE: 18 hours = 75% Multiply 75 x ECS/Y = \$2,740

SAMPLE SPECIFICATION

SCOPE

1.1 This specification is intended to cover the design, manufacture, and testing of 2 in (50 mm) through 60 in (1500 mm) Tilted Disc Check Valves suitable for pressures up to 400 psig (2750 kPa) water service.

1.2 Check Valves shall be of the Tilted Disc, metal seated, full body type capable of accepting optional bottom or top mounted oil dashpots.

CONNECTIONS

2.1 The valves shall be provided with drilled flanges in accordance with ANSI B16.1 for Class 125 or Class 250 iron flanges and ANSI B16.42 for Class 150 ductile iron flanges. Iron flanges shall be flat faced. PN10, PN16, PN25, also available.

2.2 Flanged inspection ports shall be provided upstream and downstream of the valve disc for inspection or use with optional dashpots on 6 in (150 mm) and larger valves.

DESIGN

3.1 The valve body shall consist of two sections bolted together as a central diagonal flange inclined at an angle of 55 degrees.

3.2 The eccentric pivot trunnions shall be located to divide the disc into approximately 1/3 and 2/3 proportions and also allow the seating surface of the disc to rotate away from the seating surface of the seat ring without contact. Clearance shall be provided between the pivot pin and bushing when the disc is seated to prevent binding and to ensure a tight seal.

3.3 The flow area through the valve body inlet and outlet shall be equal to the nominal pipe size and gradually increase to an area 40 percent greater at the valve seat. Cv coefficients shall be verified by an independent laboratory.

3.4 A position indicator shall be supplied on 6 in (150 mm) and larger valves.

3.5 The valve disc and seat shall have a seating surface finish of 32 micro-inch or better to ensure positive seating at all pressures. The leakage rate shall not exceed one-half of the allowable rate allowed by AWWA Standard C508 or 0.5 oz (15 ml) per hour per inch (mm) of valve size.

3.6 6 in (150 mm) and larger valves shall be capable of accepting a field installed bottom mounted oil dashpot.

MATERIALS

4.1 The valve body shall be constructed of ASTM A126 Class B cast iron for Class 125 and Class 250 valves up to 10 in (250 mm). 12 in (300mm) and larger Class 250 and Class 150 valves shall be constructed of ductile iron ASTM A536 Grade 65-45-12.

4.2 The disc in sizes up to 10 in (250mm) shall be one-piece construction with integral seat and constructed of ASTM B271 Alloy C95400 aluminum bronze. 12 in (300mm) and larger discs shall be ASTM A126 Class B cast iron. Discs furnished for 12 in (300mm) and larger valves with top mounted oil dashpots shall be constructed of ASTM A536 Grade 65-45-12 ductile iron. The disc seating ring shall be ASTM B271 Alloy C95500 centrifugally cast aluminum bronze. The mating seat ring located in the body shall be ASTM B271 Alloy C95400 centrifugally cast aluminum bronze.

4.3 The pivot pins shall be ASTM B505 Alloy C95500 aluminum bronze and shall be guided by a bushing constructed of ASTM B505 Alloy C95400 aluminum bronze.

OPTIONS

5.1 Single or double By-Pass piping shall be provided when specified.

5.2 A SCADA compatible, Nema-4 limit switch with DPDT contacts shall be provided when specified

5.3 A (bottom mounted) (top mounted) oil dashpot shall be provided when specified.

MANUFACTURE

6.1 The valves shall be hydrostatically tested at 1.5 times their rated cold working pressure. The valve interior shall be coated with an ANSI/NSF 61 certified epoxy coating.

6.2 A 20 in (500 mm) valve or larger shall be proof of design cycle tested through 250,000 cycles in the horizontal position and leak tested at the rated pressure.

6.3 Tilted Disc Check Valves shall be Val-Matic Series #9000.

* See www.valmatic.com for full spec.

PRESSURE / TEMPERATURE RATINGS

The Val-Matic Tilted Disc is offered in three different flange classes: 125, 250, and 150. This chart indicates the maximum non-shock pressures for each flange class.

NOTE: The Ductile Iron 9600 series, Class 150 is rated for 285 PSI and can be bolted directly to flanges with 150 or 125 ANSI class drilling.

MAXIMUM NON-SHOCK PRESSURE - PSI							
TEMP. °F	SERIES 9800			SERIES 9700			SERIES 9600
	CLASS 125			CLASS 250			CLASS 150
	CAST IRON			DUCTILE IRON			DUCTILE IRON
	2" - 12"	14" - 24"	30" - 60"	2" - 12"	14" - 24"	30" - 60"	2" - 60"
	50 - 300mm	350 - 600mm	750 - 1500mm	50 - 300mm	350 - 600mm	750 - 1500mm	50 - 1500mm
100°	200	150	150	400	300	300	285
150°	200	150	150	400	300	300	270
200°	190	135	115	370	280	250	260
250°	*	*	*	355	270	225	250
HYDROSTATIC TEST PRESSURE	300	230	230	600	450	450	450

* For service above 200° F use series 9700 or 9600.

QUALITY ASSURANCE

Val-Matic's quality assurance is the sum of imaginative design, solid engineering, precise manufacturing and dedicated people.

These all combine to ensure total customer satisfaction. We recognize the need for, and encourage, individual pride and the self-satisfaction which is gained in producing reliable, quality valves.

This quality attitude permeates through the corporation from the president to our newest employee.

Testing is the backbone of our quality assurance. Every Tilted Disc Check Valve is 100% tested including hydrostatic testing to assure the integrity of the casting and seating compositing.

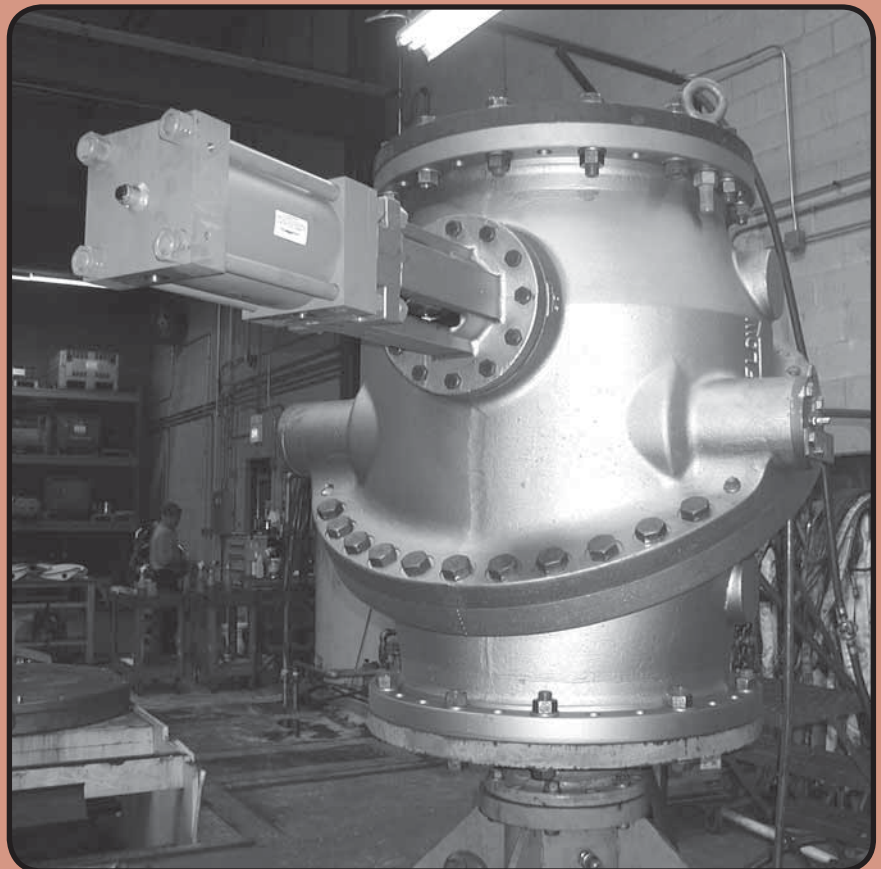

INSTALLATION DIMENSIONS AND CONSTRUCTION

Tilted Disc Check Valve

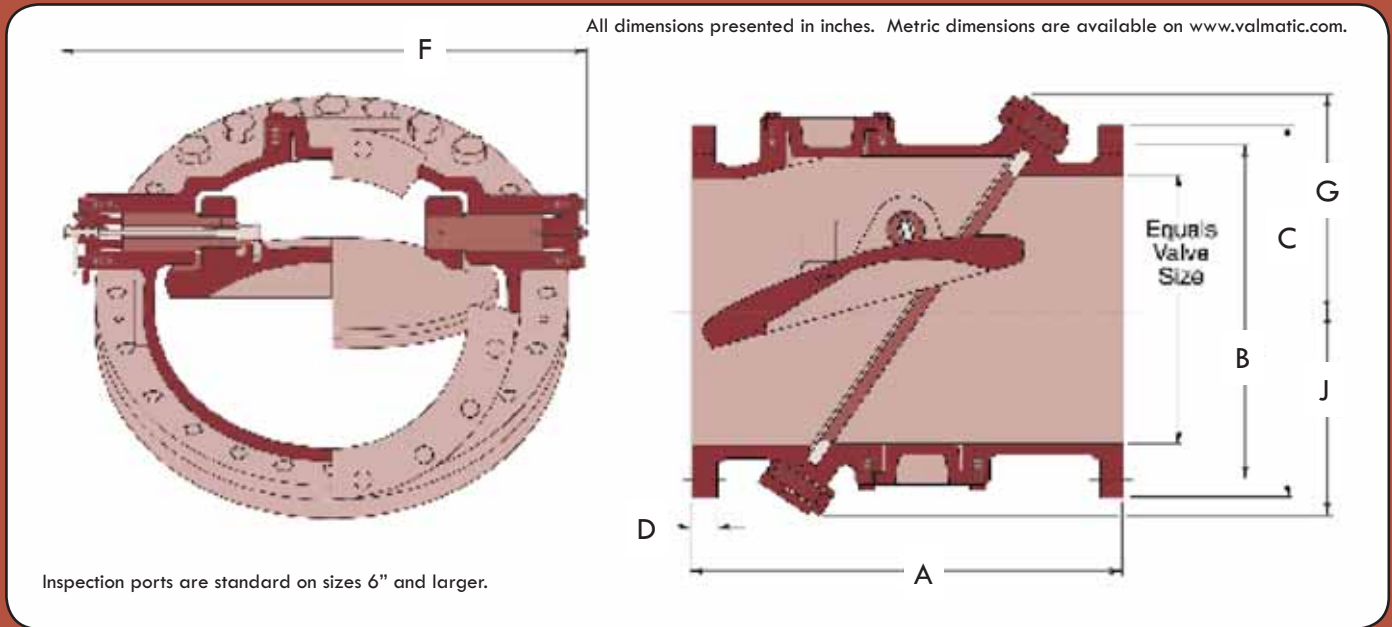

Size	ANSI Class	Model No.	A	B	C	D	F	G	J	Wt. Lbs.
2	125	9802	9.5	4.75	6	.75	11	4.25	3.75	50
	250	9702		5	6.5	.88				60
	150	9602		4.75	6	.75				55
3	125	9803	9.5	6	7.5	.94	12	4.75	4.25	65
	250	9703		6.63	8.25	1.13				75
	150	9603		6	7.5	.94				70
4	125	9804	11.5	7.5	9	.94	13	5.25	4.75	80
	250	9704		7.88	10	1.25				97
	150	9604		7.5	9	.94				87
6	125	9806	15	9.5	11	1	16	6.5	6.5	156
	250	9706		10.63	12.5	1.44				206
	150	9606		9.5	11	1				169
8	125	9808	19.5	11.75	13.5	1.13	19	8	8	295
	250	9708		13	15	1.63				331
	150	9608		11.75	13.5	1.13				312
10	125	9810	24.5	14.25	16	1.19	23	9.5	8.5	432
	250	9710		15.25	17.5	1.88				557
	150	9610		14.25	16	1.19				472
12	125	9812	24	17	19	1.25	26	11	10	622
	250	9712		17.75	20.5	2				790
	150	9612		17	19	1.25				673
14	125	9814	30	18.75	21	1.38	29	12	11.5	890
	250	9714		20.25	23	2.13				1,110
	150	9614		18.75	21	1.38				955
16	125	9816	30	21.25	23.5	1.44	32	14	14	1,160
	250	9716		22.5	25.5	2.25				1,447
	150	9616		21.25	23.5	1.44				1,256

Size	ANSI Class	Model No.	A	B	C	D	F	G	J	Wt. Lbs.
18	125	9818	33	22.75	25	1.56	36	15	15	1,408
	250	9718		24.75	28	2.38				1,770
	150	9618		22.75	25	1.56				1,509
20	125	9820	32	25	27.5	1.69	39	16	16	1,718
	250	9720		27	30.5	2.5				1,970
	150	9620		25	27.5	1.69				1,860
24	125	9824	38	29.5	32	1.88	46	19	18	2,698
	250	9724		32	36	2.75				3,402
	150	9624		29.5	32	1.88				2,925
30	125	9830	52	36	38.75	2.13	55	23	22	4,900
	250	9730		39.25	43	3				5,962
	150	9630		36	38.75	2.13				5,310
36	125	9836	59.5	42.75	46	2.38	65	27	24	7,500
	250	9736		46	50	3.38				9,003
	150	9636		42.75	46	2.38				8,138
42	125	9842	62.5	49.5	53	2.63	73	32	27	10,500
	250	9742		52.75	57	3.69				12,510
	150	9642		49.5	53	2.63				11,400
48	125	9848	65	56	59.5	2.75	82	37	32	13,800
	250	9748		60.75	65	4				16,770
	150	9648		56	59.5	2.75				15,000
54	125	9854	78	62.75	66.25	3	90.88	39	36	17,500
	250	9754		*	*	*				21,600
	150	9654		62.75	66.25	3				19,000
60	125	9860	87	69.25	73	3.13	92	44.25	42	23,000
	250	9760		*	*	*				28,258
	150	9660		69.25	73	3.13				25,000

Flanged ends conform to ANSI specifications B16.1 and B16.42. Flanged ends conforming to BS, DIN, and ISO specifications are also available.

INSTALLATION DIMENSIONS AND CONSTRUCTION

Tilted Disc Check Valve with Bottom Mounted Oil Dashpot



Integral disc ring and bushings on sizes 10" and smaller



Disc position indicator standard

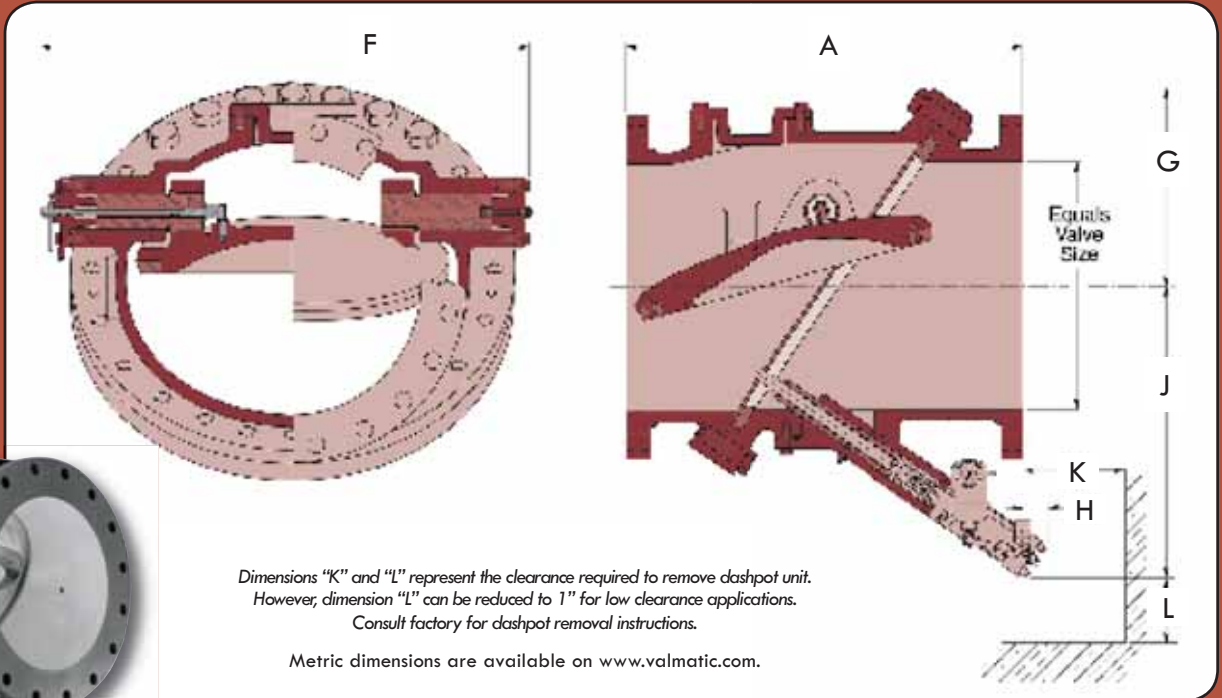

Size	ANSI Class	Model No.	A	F	G	H	J	K	L	Wt. Lbs.
6	125	9806B								174
	250	9706B	15	16	6.5	9	16	12	3	224
	150	9606B								187
8	125	9808B								317
	250	9708B	19.5	19	8	8	17	11	4	353
	150	9608B								334
10	125	9810B								454
	250	9710B	24.5	23	9.5	5	18	9	5	579
	150	9610B								494
12	125	9812B								656
	250	9712B	24	26	11	7	20	11	5	824
	150	9612B								707
14	125	9814B								924
	250	9714B	30	29	12	4	21	8	5	1,144
	150	9614B								989
16	125	9816B								1,214
	250	9716B	30	32	14	5	23	9	5	1,501
	150	9616B								1,310
18	125	9818B								1,462
	250	9718B	33	36	15	3	24	7	5	1,824
	150	9618B								1,563
20	125	9820B								1,772
	250	9720B	32	39	16	3	25	8	6	2,024
	150	9620B								1,914

Size	ANSI Class	Model No.	A	F	G	H	J	K	L	Wt. Lbs.
24	125	9824B								2,752
	250	9724B	38	46	19	1*	27	4	6	3,456
	150	9624B								2,979
30	125	9830B								5,024
	250	9730B	52	55	23	1*	35	6	8	6,086
	150	9630B								5,434
36	125	9836B								7,624
	250	9736B	59.5	65	27	5*	39	2	8	9,127
	150	9636B								8,262
42	125	9842B								10,670
	250	9742B	62.5	73	32	5*	43	5	8	12,680
	150	9642B								11,570
48	125	9848B								13,970
	250	9748B	65	82	37	2*	52	8	8	16,940
	150	9648B								15,170
54	125	9854B								17,720
	250	9754B	78	89	39	7*	55	5	8	21,820
	150	9654B								19,220
60	125	9860B								23,220
	250	9760B	87	99	42	7*	64	5	8	28,478
	150	9660B								25,220

Flanged ends conform to ANSI specifications B16.1 and B16.42. Dimensions are shown on previous page. Flanged ends conforming to BS, DIN, and ISO specifications are also available.

*Dimension "H" does not extend beyond flange face for valve sizes 24" and larger. Dimension shown is within the flange face. All dimensions presented in inches.

INSTALLATION DIMENSIONS AND CONSTRUCTION

Tilted Disc Check Valve with Top Mounted Oil Dashpot

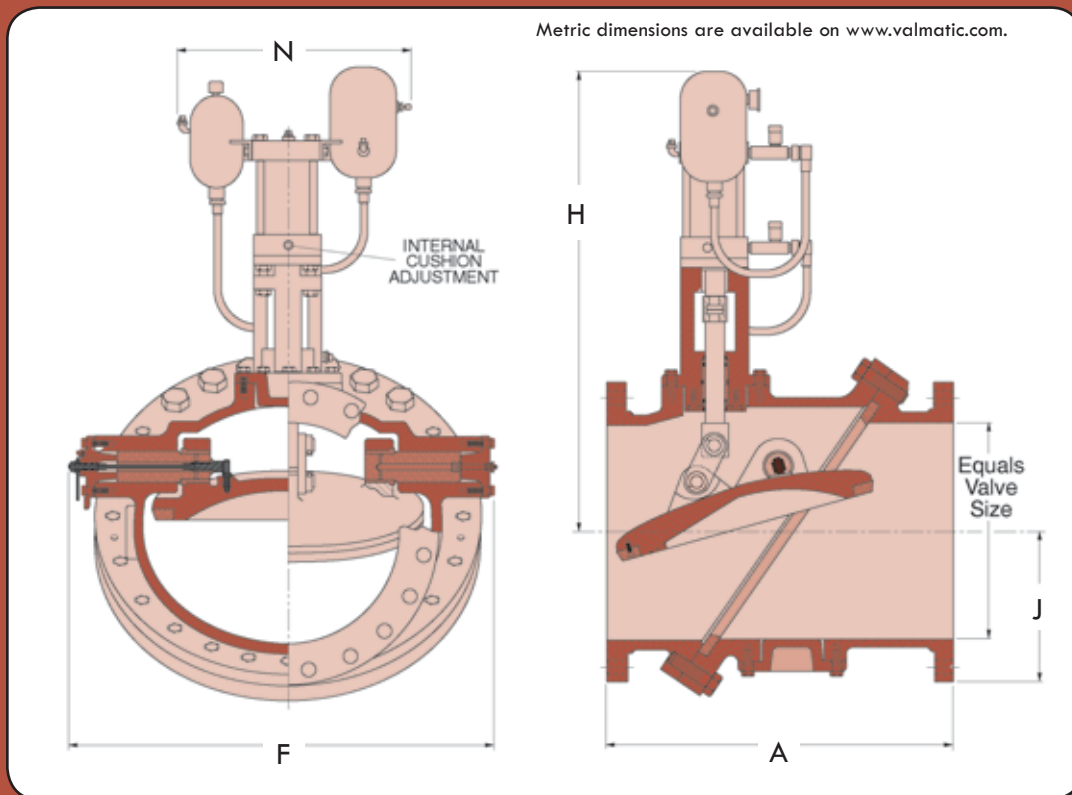

Disc position indicator standard



Integral disc ring and bushings on sizes 10" and smaller

Valve Size	ANSI Class	Model No.	A	F	H	J	N	Wt. Lbs.
6	125	9806T						196
	250	9706T	15	16	23	6.5	12	246
	150	9606T						209
8	125	9808T						381
	250	9708T	19.5	19	29	8	17	417
	150	9608T						398
10	125	9810T						518
	250	9710T	24.5	23	31	8.5	17	643
	150	9610T						558
12	125	9812T						764
	250	9712T	24	26	34	10	21	927
	150	9612T						810
14	125	9814T						1,035
	250	9714T	30	29	36	13	21	1,249
	150	9614T						1,094
16	125	9816T						1,420
	250	9716T	30	32	43	14	24	1,697
	150	9616T						1,506
18	125	9818T						1,677
	250	9718T	33	36	45	15	24	2,206
	150	9618T						1,765
20	125	9820T						2,135
	250	9720T	32	39	53	16	28	2,369
	150	9620T						2,259

Valve Size	ANSI Class	Model No.	A	F	H	J	N	Wt. Lbs.
24	125	9824T						3,136
	250	9724T	38	46	56	18	28	3,814
	150	9624T						3,337
30	125	9830T						5,656
	250	9730T	52	55	66	24	36	6,670
	150	9630T						6,018
36	125	9836T						8,338
	250	9736T	59.5	65	78	24	36	9,753
	150	9636T						8,888
42	125	9842T						11,670
	250	9742T	62.5	73	89	27	43	13,555
	150	9642T						12,445
48	125	9848T						15,040
	250	9748T	65	82	99	32	43	17,860
	150	9648T						16,090
54	125	9854T						19,218
	250	9754T	78	90.88	122.5	36	48	23,318
	150	9654T						20,718
60	125	9860T						25,514
	250	9760T	87	99	120	41.75	60	30,572
	150	9660T						27,314

Flanged ends conform to ANSI specifications B16.1 and B16.42. Flanged ends conforming to BS, DIN, and ISO specifications are also available. All dimensions presented in inches.

Make the change to **QUALITY!** Specify **VAL-MATIC®**

Val-Matic's quality of design and meticulous workmanship has set the standards by which all others are measured. Quality design features such as Type 316 stainless steel trim as standard on Air Release, Air/Vacuum and Combination Air Valves...combined resilient/metal to metal seating for Silent Check® Valves...stabilized components that provide extended life of the Dual Disc® Check Valves...high strength and wear resistant aluminum bronze trim as standard for Tilted Disc® Check valves...unrestricted full flow area through Swing-Flex® Check Valves...heavy duty stainless steel screened inlet on Sure Seal® Foot Valves...a Cam-Centric®

Plug Valve with more requested features than any other eccentric plug valve, and the American-BFV® Butterfly Valve that provides a field replaceable seat without the need for special tools. These features coupled with our attention to detail put Val-Matic valves in a class by themselves.

Val-Matic is totally committed to providing the highest quality valves and outstanding service to our customers. Complete customer satisfaction is our goal.



VAL-MATIC VALVE AND MANUFACTURING CORP.

905 RIVERSIDE DRIVE * ELMHURST, IL 60126

630/941-7600 * FAX: 630/941-8042

www.valmatic.com

valves@valmatic.com