

Heavy Duty General Purpose Lugged Style Knifegate Valve

Features

- Compact design for easy installation and maintenance
- Both 304SS and 316SS valves available
- Available in metal & resilient seat
- Uni & bi-directional design
- One piece integral cast body, chest and lugs
- Integral cast in gate wedges minimize flow obstructions
- High flow rates with low pressure drops
- Gate guides to support gate
- Complies with AS6401 & MSS SP-81 face to face dimensions
- Every valve pressure tested
- Gate machined over full length for optimum sealing
- 50 to 1200mm sizes available, 50 to 600mm kept in stock
- 10 bar pressure rating
- Specifically formulated PTFE impregnated packing material for increased service life and lower friction
- Specialised packing for chemical resistant or abrasive applications available on request
- Available with a variety of actuators including handwheel, chain wheel, quick acting lever, geared, electric, air or hydraulic cylinder actuator

Options

- Bonneted, non-rising stem adapter, deflection cones, positioners, limit switches, solenoids, pneumatic failsafe & shrouds.



Applications

The Valveco Heavy Duty General Purpose Knifegate Valve is designed for a wide range of applications such as:

- Waste Water & Water
- Mining
- Fly Ash Handling Plants
- Bulk Conveying
- Corrosive Environments
- Pulp & Paper
- Food & Beverage
- Chemical Plants

Manual Actuation

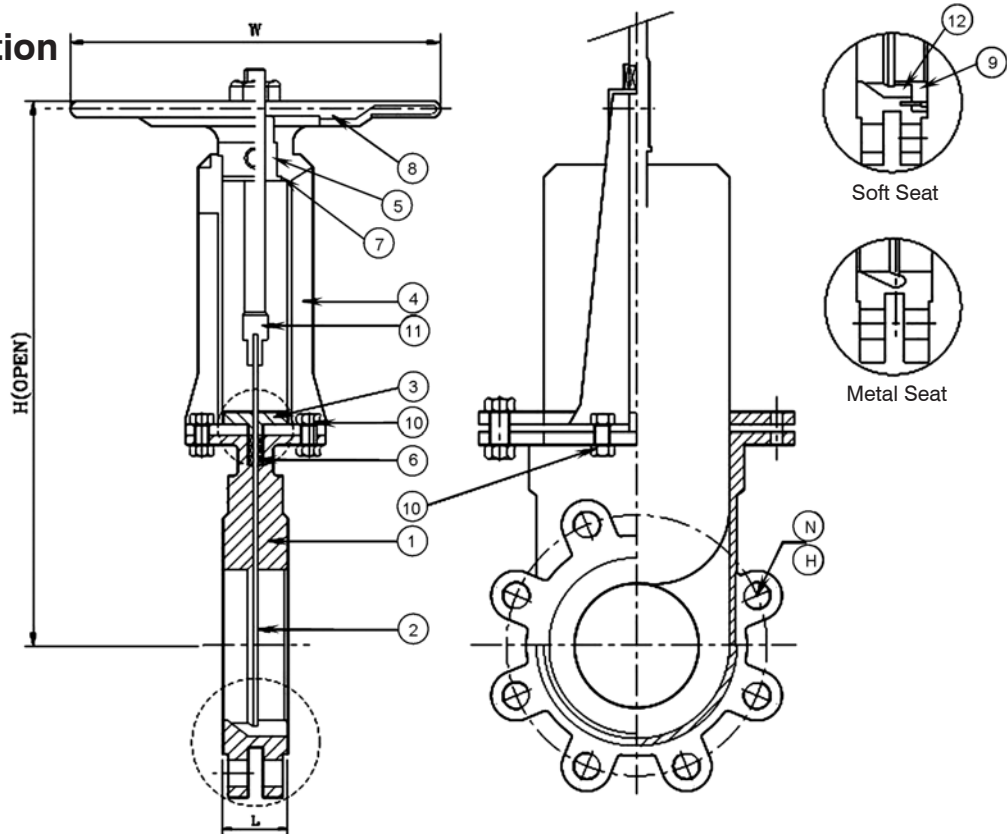

Standard Materials

No.	Part Name	Material Code (ASTM)
1	Body	SS304, 316 or 316L (A351-CF8)
2	Gate	SS304, 316 or 316L (A351-CF8)
3	Packing Gland	SS304, 316 or 316L (A351-CF8)
4	Super Structure	SS304, 316 or 316L (A351-CF8)
5	Sleeve	Bronze Casting (C83600)
6	Packing	PTFE Impregnated Braided Fibre
7	Thrust Bearing	2" - 12": Thrust Plate (Bronze) 14" - 24": 51112
8	Hand Wheel	Cast Iron
9	Seat Ring	SS304, 316 or 316L (A351-CF8)
10	Fasteners	SS304, 316 or 316L (A351-CF8)
11	Clevis	SS304, 316 or 316L (A351-CF8)
12	Resilient Seat Replaceable Seat	Viton NBR, EPDM, PTFE, Polyamide

Dimensions

Class	Size	In	2	2½	3	4	5	6	8	10	12	14	16	18	20	24
		mm	50	65	80	100	125	150	200	250	300	350	400	450	500	600
10 Bar & 150lb	L mm	48	51	51	51	57	57	70	70	76	76	89	89	114	114	
	H mm	350	410	440	520	595	660	880	1025	1190	1355	1530	1690	1880	2200	
	PCD mm	114	127	146	178	210	235	292	356	406	470	521	584	641	756	
	W mm	200	200	200	225	250	250	280	350	400	400	450	450	600	600	
	N-H	4-M16	4-M16	4-M16	4-M16	8-M16	8-M16	8-M16	8-M20	12-M20	12-M24	12-M24	12-M24	16-M24	16-M27	
	Weight (kg)	9.5	12	13	16	19	22	34	53	65	90	145	180	227	282	

*other flange drilling available

Pneumatic Actuation

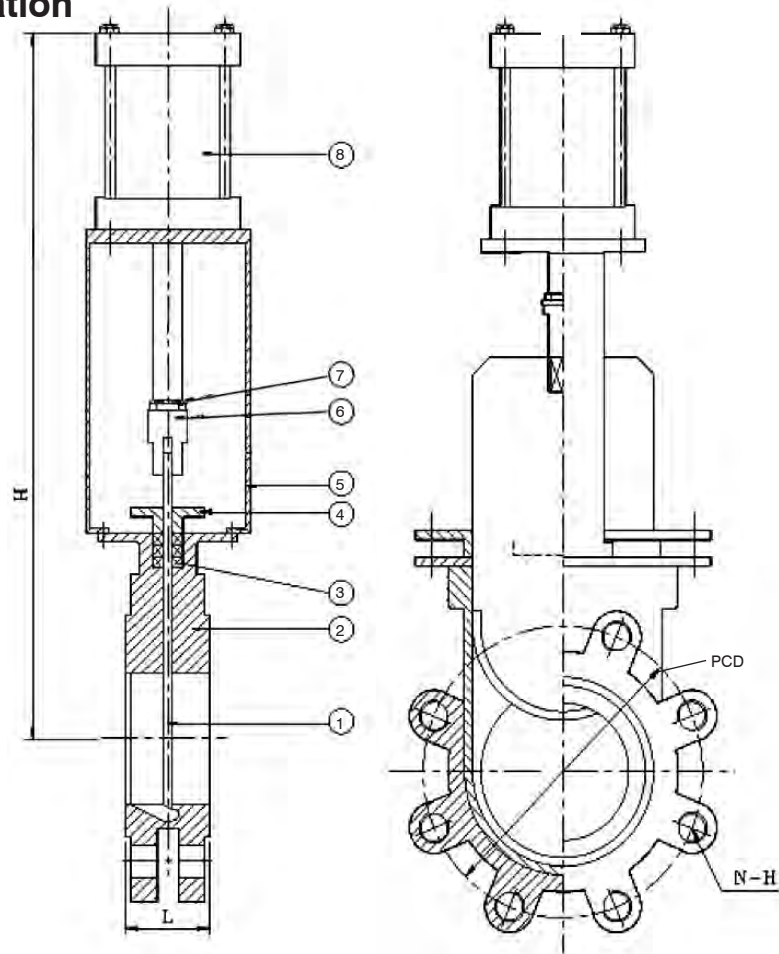

Standard Materials

No.	Part Name	Material Code (ASTM)
1	Body	SS304, 316 or 316L (A351-CF8)
2	Gate	SS304, 316 or 316L (A351-CF8)
3	Packing	PTFE Impregnated Braided Fibre
4	Packing Gland	SS304, 316 or 316L (A351-CF8)
5	Super Structure	SS304, 316 or 316L (A351-CF8)
6	Clevis	SS304
7	Piston Rod	SS304
8	Cylinder	Aluminium or Fibreglass

Dimensions

Class	Size	In	2	2½	3	4	5	6	8	10	12	14	16	18	20	24
		mm	50	65	80	100	125	150	200	250	300	350	400	450	500	600
10 Bar & 150lb	L mm	48	51	51	51	57	57	70	70	76	76	89	89	114	114	
	H mm	500	561	574	675	750	815	966	1181	1340	1448	1648	1834	2020	2120	
	PCD mm	114	127	146	178	210	235	292	356	406	470	521	584	641	756	
	N-H	4-M16	4-M16	4-M16	4-M16	8-M16	8-M16	8-M16	8-M20	12-M20	12-M24	12-M24	12-M24	16-M24	16-M27	
	Weight (kg)	11	13	15	21	25	31	58	103	137	158	172	202	256	494	

*other flange drilling available

Note

The designs, materials, dimensions and specifications shown are subject to change without notice due to our continuing program of product development.



NSW

Wyong - Head Office

10 Hereford Street, Berkeley Vale NSW 2261
PO Box 5010 Chittaway NSW 2261
Tel: +61 (0)2 4389 6191
Fax: +61 (0)2 4389 6198
Email: info@hmagroup.com.au

Sydney

13 Sirius Road Lane Cove, NSW 2066
Tel: +61 (0)2 9428 7300
Fax: +61 (0)2 9428 7399
Email: sydney@hmagroup.com.au

QLD

Brisbane

4th Floor, 49 Sherwood Road, Toowong QLD 4066
PO Box 106, Toowong QLD 4066
Tel: +61 (0)7 3859 6800
Fax: +61 (0)7 3859 6869
Email: brisbane@hmagroup.com.au

Mackay

22-30 Southgate Drive,
Southgate Industrial Park, Paget QLD 4740
PO Box 6221, Mackay Mail Centre QLD 4741
Tel: +61 (0)7 4998 6900
Fax: +61 (0)7 4998 6999
Email: mackay@hmagroup.com.au

Gladstone

9 Neil Street, Gladstone QLD 4680
PO Box 1731, Gladstone QLD 4680
Tel: +61 (0)7 4978 3128
Fax: +61 (0)7 4978 3127
Email: gladstone@hmagroup.com.au

Townsville

PO Box 347, Aitkenvale QLD 4814
Tel: +61 (0)7 4728 6300
Fax: +61 (0)7 4728 6388
Mobile: +61 (0)417 996 694
Email: townsville@hmagroup.com.au

WA

Perth

119 Dowd Street, Welshpool WA 6106
Tel: +61 (0)8 6254 9500
Fax: +61 (0)8 6254 9599
Email: perth@hmagroup.com.au

VIC

Melbourne

PO Box 204, Narre Warren VIC 3805
Mobile: +61 (0)429 176 688
Email: melbourne@hmagroup.com.au

Morwell

8 Jones Road, Morwell Vic 3840
PO Box 647, Morwell Vic 3840
Tel: +61 (0)3 5136 8400
Fax: +61 (0)3 5136 8499
Email: morwell@hmagroup.com.au

SA

Adelaide

PO Box 1280, North Haven SA 5018
Tel: +61 (0)8 8341 8067
Fax: +61 (0)8 8341 8067
Mobile: +61 (0)437 460 032
Email: adelaide@hmagroup.com.au

NEW ZEALAND

Hamilton - NZ Head Office

Unit 14, 9 Karewa Place, Pukete, Hamilton NZ 3200
PO Box 10102, Te Rapa, Hamilton NZ 3241
Tel: +64 (0)7 847 1880
Fax: +64 (0)7 847 1883
Email: hamilton@hmagroup.co.nz

Wellington

Mobile: +64 (0)272 612 744
Fax: +64 (0)7 847 1883
Email: wellington@hmagroup.co.nz

Dunedin

Mobile: +64 (0)275 116 694
Fax: +64 (0)7 847 1883
Email: dunedin@hmagroup.co.nz

Halley & Mellowes Australasia Group of Companies