

## V-3E Type - Size: 1/4"-4"



### Stainless Steel

**AISI-316** (EN10213-4 1.4408) (ASTM-A351-CF8M)

**AISI-304** (EN10213-4 1.4308) (ASTM-A351-CF8)

### Carbon Steel

**S-20C** (EN10213-2 1.0619) (ASTM-A216-WCB)

### Features:

- Pipe thread in accordance with ANSI B2.1, BS21 1973, DIN 259/2999, ISO 228
- Lug Body
- Blow-out proof stem/Full port
- Investment casting body and cap
- 1000PSI (69 Bar) W.O.G.

### Option:

Locking device

No	Name of Parts	Material
1	Body	ASTM CF8M A351
2	CAP	ASTM CF8M A351
3	Ball	ASTM CF8M A351
4	Ball Seat	PTFE
5	Joint Gasket	PTFE
6	Stem	AISI 316
7	Thrust Washer	PTFE
8	Stem Packing	AISI 304
9	Gland Nut	AISI 304
10	Handle	AISI 304
11	Stem Washer	AISI 304
12	Stem Nut	AISI 304
13	Plastic Cover	Plastic
14	Lock Device	AISI 304
15	Bolt	AISI 304
16	Spring Washer	AISI 304
17	Hex Nut	AISI 304

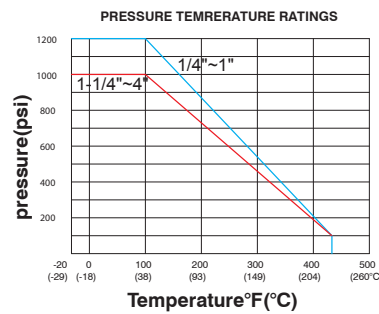
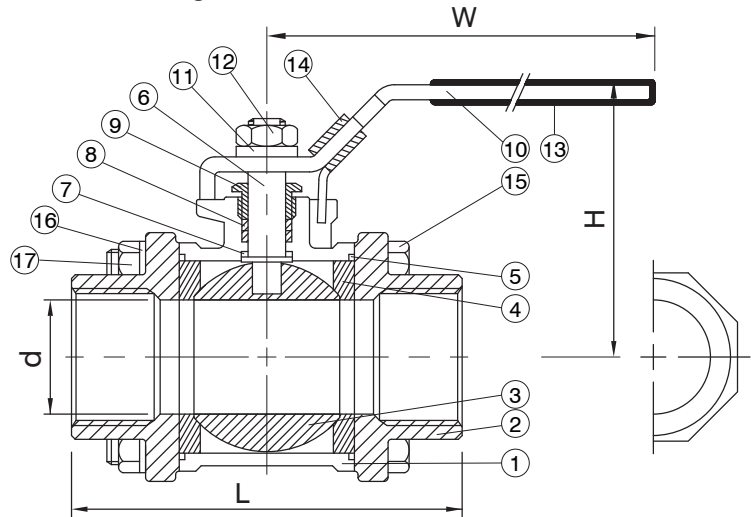

Size	d	L	H	W	Cv Factor	Torque Inch-Lbs	Kgs
1/4"	11.6	52	48	100	6.6	40	0.29
3/8"	11.6	52	48	100	7.9	40	0.29
1/2"	15	63.4	52	100	10	43	0.39
3/4"	20	71	61	127	25	65	0.61
1"	25	80.6	65	127	35	101	0.86
1-1/4"	32	94	79	154	46	158	1.37
1-1/2"	38	104	83	154	80	187	2.04
2"	50	126.4	97	192	110	230	3.74
2-1/2"	65	160	135	244	360	1380	10.2
3"	80	179.5	144	244	360	1380	10.2
4"	100	220	157	280	820	2400	24.1

### Note

The designs, materials, dimensions and specifications shown are subject to change without notice due to our continuing program of product development.